

The British Sundial Society



BULLETIN

VOLUME 19(iv)

December 2007

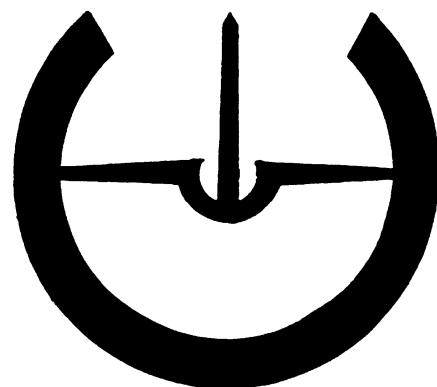

GUIDELINES FOR CONTRIBUTORS

1. The editor welcomes contributions to the *Bulletin* on the subject of sundials and gnomonics; and, by extension, of sun calendars, sun compasses and sun cannons. Contributions may be articles, photographs, drawings, designs, poems, stories, comments, notes, reports, reviews. Material which has already been published elsewhere in the English language, or which has been submitted for publication, will not normally be accepted. Articles may vary in length, but text should not usually exceed 4500 words.
2. Format: The preferred format for text is MS Word or text files sent by email to john.davis@btinternet.com. Material can also be sent on CD or as a single-sided typescript, single- or double-spaced, A4 paper.
3. Figures: For photographs, colour or black-and-white prints as large as possible (up to A4). Slides and transparencies are also acceptable. Pictures can be sent electronically as separate jpg (do not over-compress) or tif files—do not embed them in Word files. For email attachments, do not exceed 10 Mbytes per message. Tables should be treated as figures and numbered as part of the same sequence. Drawings and diagrams should be in clear, strong black lines (not pencil) on a white background. Each figure illustrating an article should carry on the back the author's name and a number indicating its relative position in the text (Fig. 1, Fig. 2 etc...). Label the top of the figure if it is not obvious. Captions for the figures should be written on a separate sheet in numerical order. They should be sufficiently informative to allow the reader to understand the figure without reference to the text.
4. Mathematics: symbols used for the common dialling parameters should follow the conventions given in the Symbols section of the *BSS Glossary* (available online on the Society's website). Consult the editor if in doubt or for help in laying out equations.
5. The *Bulletin* does not use footnotes. Where additional information is required, notes should be numbered as a Reference with a superscript number. For very long notes, use an appendix.
6. References: Sources are referred to in the text by a superscript number. They are listed in numerical order under the heading 'References' (or 'References and Notes') at the end of the article. The *Bulletin's* convention is as follows:

For books: Author's name; Title of book, in italics; Name of publisher, Place and date of publication.

For papers and articles: Author's name; Title of article in single quote-marks; Name of journal, in italics (this may be abbreviated); volume number, underlined in Arabic numerals; first and last page numbers; date, in brackets.

Examples:

A.E. Waugh: *Sundials, their theory and construction*, Dover, New York, (1973).

D. Colchester: 'A Polarized Light Sundial', *Bull BSS*, **96.2**, 13-15 (1996)

A.A. Mills: 'Seasonal Hour Sundials', *Antiquarian Horol.* 19, 142-170 (1990)

W.S. Maddux: 'The Meridian on the Shortest Day', *NASS Compendium*, 4, 23-27 (1997).

If you simply wish to give a short list of books associated with the subject of the article, this may be given at the end of the article under the heading 'Bibliography', using the convention as given for 'Books' above.

7. Acknowledgements: These should be as brief as is compatible with courtesy.
8. The address of the author will normally be printed at the end of the article unless the author, when submitting the article, expresses a wish that this should not be done.
9. Copyright: The copyright of an article is held by the author. The copyright of photographs belongs to the photographer; authors who use photographs other than their own should obtain permission and should acknowledge the source in the caption. Authors who re-publish elsewhere material already published in the *Bulletin* are asked to refer to the *Bulletin* in the re-publication.

Please send all original material to:

The BSS Editorial Office

Orchard View, Tye Lane

Flowton

Ipswich

Suffolk, IP8 4LD

john.davis@btinternet.com

Front cover: *The horizontal dial by Thomas Tompion (1639-1713) on a ledge outside the window of the Pump Room overlooking the King's Baths, Bath. The dial is relatively plain as it was designed to accompany the very large longcase clock which Tompion made and presented to the city in 1709. The clock, which is on display in the Pump Room, features an Equation of Time mechanism. Photos: John Davis.*

Back cover: *The Saxon dial at North Stoke, Oxfordshire. The church, dedicated to St Mary the Virgin, is from the 13th century and replaces a Norman one which in turn was probably on the site of a Saxon one. The figure, said to represent Our Lord, actually has arms as well as hands but these were covered up in 1902. Photo: Tony Ashmore.*



BULLETIN

OF THE BRITISH SUNDIAL SOCIETY

ISDN 0958-4315

VOLUME 19(iv) - December 2007

CONTENTS

- 145. Editorial
- 146. Daniel O'Connell, Teacher and Slate Sundial Maker - *Michael J Harley*
- 151. Newbury Meeting 2007 - *John Lester*
- 152. A Strange Creature - *Ian R Butson*
- 153. Ben Jones: Letter Carver, Sculptor and Sundial Maker - *Douglas Bateman*
- 156. Astrolabes: Pt.3 Arabic Astrolabes - *Tony Ashmore*
- 161. New Dials
- 164. The Method of Equal Altitudes or the Indian Circle - *Hugh McCague*
- 172. Clock Ephemeris and Sundials - *John Davis*
- 173. Readers' Letters - *Maes, Bailey, King, Head, Lester*
- 176. Making Portable Dials in Silver - *Jackie Jones*
- 178. Postcard Potpourri 6 - *Peter Ransom*
- 179. John Rowell: Plumber and Stained Glass Dial Maker - *John Davis*
- 184. A Multiple Dial as a Monument to the Fishermen of Cala Figuera, Santanyi (Majorca) - *Rafael Soler Gayà*
- 187. A Dial by Richard Melville in Andover, Hampshire - *Douglas Bateman*
- 189. Book Review - *Mike Cowham*
- 190. A New Sundial Society?
- 191. Obituary: Margaret Wilson Stanier - *Patrick Powers*
- 192. Scratch (Mass) Dials: Time for a Reassessment - *Chris H K Williams*

EDITORIAL

It is with much personal sadness that I direct your attention to the obituary of Margaret Stanier on page 191 of this issue. Margaret, of course, was my predecessor as Editor and I learned a lot from her. She was well known to the sundialing community worldwide and several overseas sundial societies have sent their condolences. We will miss her at Society meetings and trips: she was a knowledgeable and enthusiastic diallist. The many issues of the *Bulletin* which she edited will stand as a memorial to her.

Enclosed with this issue you should receive a solar and lunar data card for your wallet. It had been suggested that this format would be rather more convenient than having to carry the latest *Bulletin* around with you. It also gives me an extra half-page in each issue to fill with other dialling delights! Our thanks go to Fiona Vincent for the data and Doug Bateman for the layout.

The cover pictures for the Bulletin which I have used since becoming Editor have come from a fairly small group of photographers, simply because I have selected from what has been sent in. If you feel you have some suitable pictures (with good contrast to show on the yellow backgrounds), I would be very happy to receive them.

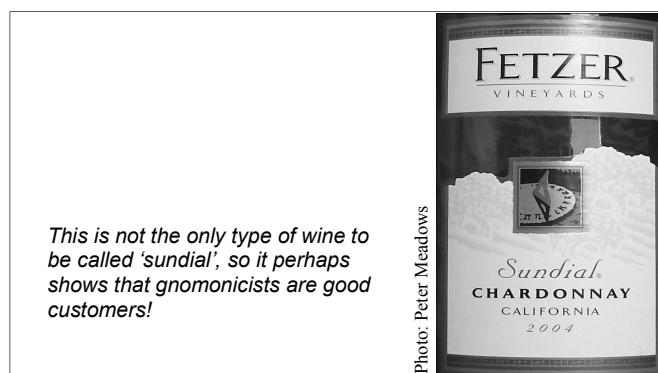

DANIEL O'CONNELL TEACHER AND SLATE SUNDIAL MAKER

MICHAEL J. HARLEY

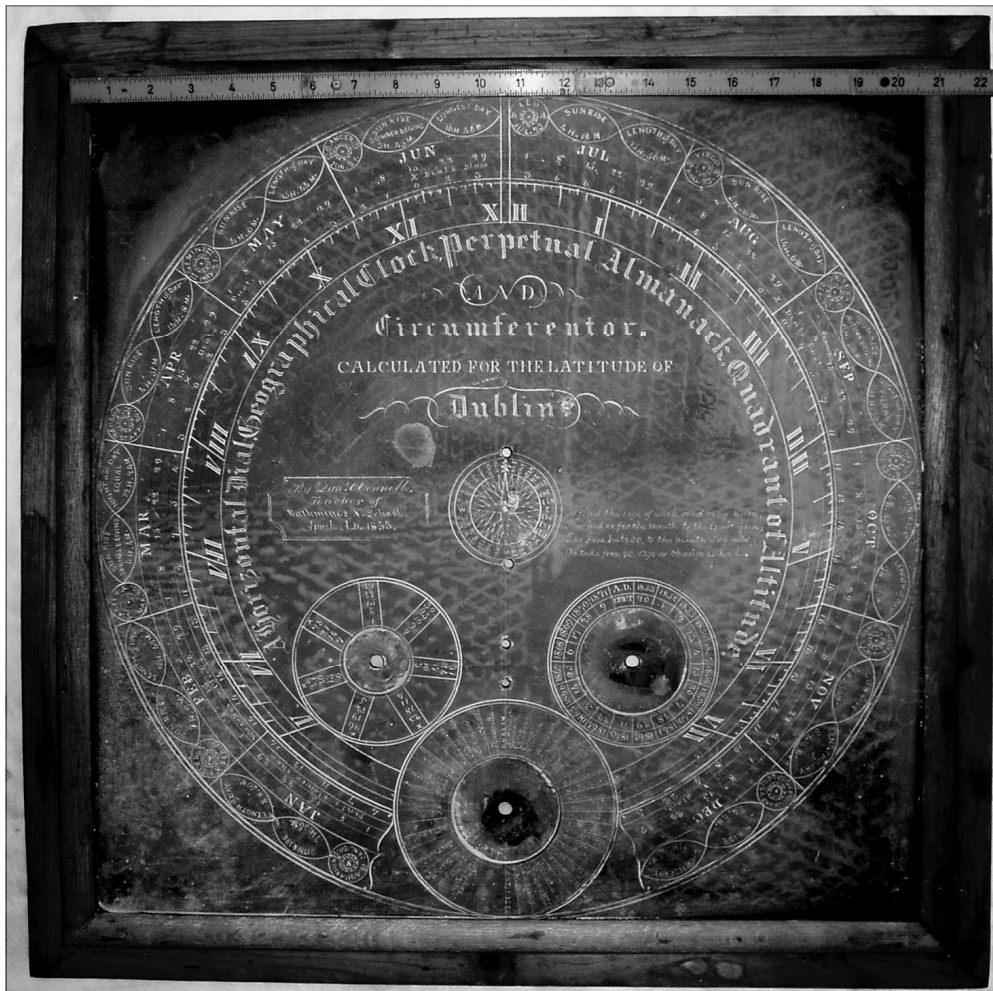

Fig. 1. 1853 O'Connell dial in the National Museum of Ireland Collection.

In the March 2006 BSS Bulletin,¹ Peter Ransom described an 1843 slate dial made by one D. O'Connell for a Rev. Spratt of Enniscean, Co. Cork, Ireland. He made reference to another dial by a maker of the same name and which is in the National Museum of Ireland (NMI) Country Life at Turlough, Castlebar, Co. Mayo.² As a result of Tony Wood's ongoing Survey of Irish Museums³ contact was made with Curatorial Assistant Silas Higgins and so, on a

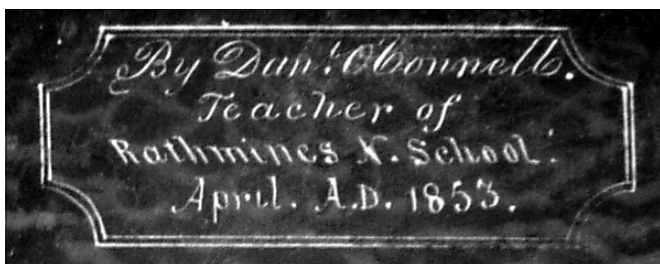

Fig. 2. Signature on the O'Connell dial

recent solo sundial safari to the West of Ireland, the NMI gave me permission to inspect and photograph the O'Connell dial (Fig. 1) in their collection.

This 21" square dark grey slate dial is mounted inside a softwood frame which no doubt has protected it from damage over the years. An inscription inside a cartouche on the dial (Fig. 2) tells us that it was made "By Dan^l O'Connell. Teacher of Rathmines N. School: April. A.D. 1853". (Rathmines is a district in Dublin; the 'N.' stands for National.)

The maker describes his dial as being "A Horizontal Dial, Geographical Clock, Perpetual Almanack, Quadrant of Altitude And Circumferentor. Calculated for the Latitude of Dublin".

The Horizontal Dial

The 14" internal and 16" external diameter chapter ring shows the time from five am to seven pm in Roman numerals, with IIII for four, and is subdivided into ½ hour, ¼ hour and 5 minute divisions. The time is read from inside the dial, that is with the observer's back to the sun. There is a ¼" noon gap to allow for the thickness of the now missing gnomon. There is a 32 point fully qualified compass rose at the centre of the plate. The angular layout of the hourlines was checked using a transparent computer-generated drawing for Latitude 52° 20' and found to be accurate.

The time is read from inside the dial, that is with the observer's back to the sun. There is a ¼" noon gap to allow for the thickness of the now missing gnomon. There is a 32 point fully qualified compass rose at the centre of the plate. The angular layout of the hourlines was checked using a transparent computer-generated drawing for Latitude 52° 20' and found to be accurate.

The Geographical Clock

Inscribed within a 5½" circle are the names of 48 distant places (See Appendix I for full listing). They are arranged at 7½° intervals going east and west, starting with Dublin at the North point and ending with the Antipodes at the South. It has a 2¼" diameter by ⅛" deep circular recess sunk into the plate and a ⅜" hole through the plate at its centre. The disk insert that would have fitted into this recess is missing

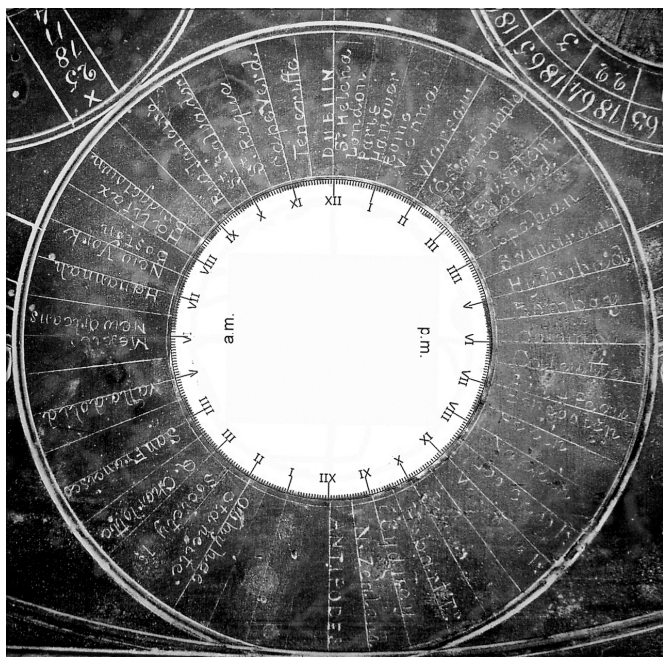

Fig. 3. O'Connell's Geographical Clock with suggested Time Disk.

but is presumed to have been made from brass because of the shallow depth of the sinking. Fig. 3 shows the author's suggestion as to what this disk might have looked like in position on the dial plate.

In operation, the inserted disk would have been rotated to align the current time on the disk with Dublin on the plate: the time of day at the other places could then be read from the disk. Alternatively, if XII noon on the disk were aligned with Dublin on the dial plate then the difference in time between Dublin and any of the others places could be calculated from the disk.

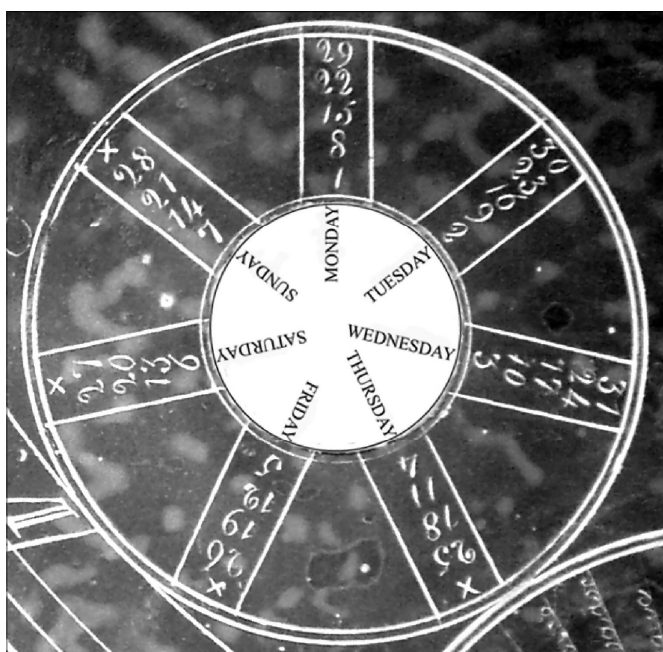

Fig. 4. Suggested Days of the Week disk for O'Connell's dial.

The Perpetual Almanack

The Perpetual Almanack is in the form of two 4" diameter circles, one for Days of the Week (Fig. 4) and one for the Age of the Moon (Fig. 5). In addition, there is a clockwise Equation of Time (EoT) ring around the outside of the hour circle. As well as the EoT values, this ring also shows the name, symbol and dates of the Zodiac as well as the time of sunrise and length of the day at the Zodiac entry. It also marks the beginning of each of the four seasons and indicates the length of the shortest and longest days (see Appendix II).

The Days of the Week

The Days of the Week circle has a 1½" diameter by 1/8" deep circular recess sunk into the plate and a 3/8" hole through the plate at its centre. The insert that would have fitted into this recess is also missing. Spiralling out from the centre in 7 columns by 5 rows are the consecutive numbers 1 to 31, the number of days in the longest month. 'x' is used to fill in the columns where there is space for a number in excess of 31. The missing insert would have had the names of the days of the week engraved on it. Align a known day with a date and all other days/dates in that month would be matched. Fig. 4 shows how the author thinks this Days/Dates disk functioned.

The Age of the Moon

The Age of the Moon circle (Fig. 5) has a 2½" diameter by 1/8" deep circular recess sunk into the plate and a 3/8" hole through the plate at its centre. The insert that would have fitted into this recess is also missing. Engraved within the outside circle are the dates of 19 consecutive years, the lunar cycle from 1853 to 1871, with their Epact numbers.



Fig. 5. Suggested index disk for O'Connell's Epact table.

A.D.	1853	1854	1855	1856	1857	1858	1859
EPACT	20	1	12	23	4	15	26

A.D.	1860	1861	1862	1863	1864	1865
EPACT	9	18	29	11	22	3

A.D.	1866	1867	1868	1869	1870	1871
EPACT	14	25	6	17	28	9

The Epact is the age of the moon at the beginning of the year i.e. the number of days since the moon was ‘new’. So had there been a new moon on January 1st 1853, the Epact would have been zero (because the moon is new, i.e. zero days ‘old’); if there had been a new moon on 29th Dec. 1852, the Epact for 1853 would have been three. So as the Epact for 1853 is 20, the first new moon of the year occurred on 10th Jan.

O’Connell engraved a formula on the dial for finding the age of the moon on any given day of the year in verse form.

*“To find the Age of each evolving moon,
The index for the month to the Epact join,
The sum, bate 30, to the month day add,
Or take from 30, Age or change is had.”*

The index is what is needed to apply this formula so it is reasonable to assume that this is what was engraved on the disk. The index for Jan is 0, for Feb it is 1 etc. Let us see if applying O’Connell’s formula to what might have been engraved on the disk (Fig. 5) works and gives us an age of 1 for the 11th Jan 1853.

*“The index for the Month (0) to the Epact (20) join
[add]” = 20*

*“The sum bate [subtract] 30” = -10 . “to the month day
(11) add” = 1.*

Success!

The Equation of Time

The EoT is shown at seven day intervals viz. 1, 8, 15, 22 and 29 including February. (See Appendix III for full EoT listing.) The changeover points, ‘0’ on the EoT value scale, are marked with an ‘x’ (Fig. 6) and the instruction “Dials slower than watches and clocks” shown at January is abbreviated to “dials fast” or “dials slow” thereafter until December when it becomes “slow”.

‘0’ values are shown at 15th April, 15th June and the 1st September and then in December something went wrong and on the value line, in line with the 22 date, he repeated the 22! He then put the ‘x’ against the value 4 on the 15th which is of course incorrect (Fig. 7). The correct position for the ‘x’ would have been between the 22 and the 29. This



Fig. 6. EoT showing 0 value marked with an ‘x’ on 15th Apr.



Fig. 7. EoT showing changeover marked with an ‘x’ on 15th Dec.

is the only engraving error noted on this elaborate plate and repeats a similar error on his 1843 dial.¹

The Quadrant of Altitude and the Circumferentor

A circumferentor is a surveying instrument which used a sighting arm for the measurement of horizontal angles. In its simplest form it consisted of two horizontal circular plates, a bottom fixed plate graduated in degrees and a top movable plate with a pointer. The observer aligns the device in the north-south direction, then swivels the movable



Fig. 8. A theodolite in the National Science Museum of Ireland.

plate horizontally and lines it up on the point of interest using the sight. The pointer indicates the angular distance travelled on the fixed plate.

A quadrant of altitude was a vertical arc for the measurement of vertical angles. With a similar plate system to the circumferentor, it was used to measure vertical angles in the range of $\pm 45^\circ$. These two instruments were later amalgamated to become the theodolite. O'Connell's instrument may well have resembled the theodolite in the National Science Museum of Ireland,⁴ shown in Fig.8.

The additional holes in the dial plate between the Days/Dates and Age of the Moon circles were probably used to hold the Quadrant/Circumferentor in place.

In 1857, at the age of 43 years, Daniel O'Connell left Rathmines National School in Dublin and moved to Shrule, Co. Mayo, as Master of a newly built school there at a salary of £20 per annum. He was accompanied by Margaret O'Connell, a teacher aged 23, who was paid an income of £10 per annum. He appears to have brought his dial with him as it was purchased from a resident of Shrule in 1963 by the NMI. It seems likely that this dial was a teaching aid rather than a functioning sundial. Whatever his teaching abilities, O'Connell certainly was a master engraver who used a variety of lettering styles, number systems and embellishments to produce this exceptional dial. Enquiries are ongoing in Shrule to see if any more of O'Connell's dials have survived and there is no doubt that Master O'Connell was also the maker of the 1843 dial described by P. Ransom, referred to earlier.

Appendix I — Place names on the Geographical Clock

East of Dublin				West of Dublin			
Place Name	Time on Disk	Implied Long.	Modern Long.	Place Name	Time on Disk	Implied Long.	Modern Long.
DUBLIN	NOON	7° 30' W	6° 16' W	DUBLIN	NOON	7° 30' W	6° 16' W
St. Helena	NOON	7° 30' W	5° 43' W	Teneriffe	11:30 AM	15° 00' W	16° 15' W
London	12:30 PM	00° 00'	00° 00'	Cape Verd	11:00 AM	22° 30' W	23° 52' W
Paris	12:30 PM	00° 00'	2° 20' E	S. Roque	10:30 AM	30° 00' W	35° 16' W
Hanover	1:00 PM	7° 30' E	9° 44' E	S. Salvador	10:00 AM	37° 30' W	38° 30' W
Rome	1:00 PM	7° 30' E	12° 29' E	Rio Janeiro	9:30 AM	45° 00' W	43° 14' W
Vienna	1:30 PM	15° 00' E	16° 25' E	No name	9:00 AM	52° 30' W	
Warsaw	2:00 PM	22° 30' E	21° 01' E	Bridgetown	8:30 AM	60° 00' W	59° 29' W
Constantinople	2:30 PM	30° 00' E	29° 03' E	Halifax	8:00 AM	67° 30' W	63° 34' W
Cairo	2:30 PM	30° 00' E	31° 15' E	Boston	7:30 AM	75° 00' W	71° 02' W
Jerusalem	3:00 PM	37° 30' E	35° 14' E	New York	7:30 AM	75° 00' W	74° 00' W
Bagdad	3:30 PM	45° 0' E	44° 24' E	Havannah	7:00 AM	82° 30' W	82° 23' W
Ispahan	4:00 PM	52° 30' E	51° 41' E	N. Orleans	6:30 AM	90° 00' W	90° 05' W
Samarcan	4:30 PM	60° 00' E	66° 48' E	Mexico	6:00 AM	97° 30' W	99° 09' W
Hyderabad	5:00 PM	67° 30' E	78° 29' E	No name	5:30 AM	105° 00' W	
Bombay	5:30 PM	75° 00' E	72° 50' E	Valladolid	5:00 AM	112° 30' W	
Illegible	6:00 PM	82° 30' E		No name	4:30 AM	120° 00' W	
Calcutta	6:30 PM	90° 00' E	88° 22' E	San Francisco	4:00 AM	127° 30' W	122° 25' W
Illegible	7:00 PM	97° 30' E		Q. Charlotte	3:30 AM	135° 00' W	132° 05' W
Benecolen	7:00 PM	97° 30' E	102° 30' E	No name	3:00 AM	142° 30' W	
Pekin	7:30 PM	105° 00' E	116° 37' E	Society I ^s	2:30 AM	150° 00' W	148° 04' W
Nankin	8:00 PM	112° 30' E	118° 47' E	Otaheite	2:00 AM	157° 30' W	149° 34' W
Illegible	8:30 PM	120° 00' E		Oahyhee	2:00 AM	157° 30' W	
Illegible	9:00 PM	127° 30' E		No name	1:30 AM	165° 00' W	
No name	9:30 PM	135° 00' E		No name	1:00 AM	172° 30' W	
Illegible	10:00 PM	142° 30' E		No name	12:30 AM	180° 00' W	
Hobart I ^s	10:30 PM	150° 00' E	147° 20' E	ANTIPODES	MIDNIGHT	172° 30' E	172° 44' E
Sydney	11:00 PM	157° 30' E	151° 13' E				
N. Zealand	11:30 PM	165° 00' E	175° 35' E				
ANTIPODES	MIDNIGHT	172° 30' E	173° 44' E				

Made for Dublin, Ireland. Longitude 6° 16' W (25 mins 4 secs of time).
Place names arranged on dial at 7½ degree (30 mins of time) intervals

Appendix II — Solar Data

Aquarius Jan. 20 Sunrise 7H. 56M. Length of day 8H. 50M. JAN	Pisces Feb. 19 Sunrise 7H. 9M. Length of day 10H. 40M. FEB	Aries Apr. 20 Sunrise 6H. 4M. Night and Day Equal 12H. 24M. MAR
Taurus Apr. 20 Sunrise 4H. 51M. Length of day 14H. 8M. APR	Gemini May 21 Sunrise 4H. 0M. Length of day 15H. 44M. MAY	Cancer Jun. 21 Sunrise 3H. 45M. Summer Begins Longest Day 16H. 46M. JUN
Leo Jul 23 Sunrise 4H. 12M. Length of day 15H. 56M. JUL	Virgo Aug 23 Sunrise 5H. 0M. Length of day 14H. 6M. AUG	Libra Sep. 23 Sunrise Autumn Begins 5H. 50M. Night and Day Equal 11H. 50M. SEP
Scorpio Oct. 23 Sunrise 6H. 40M. Length of day 9H. 56M. OCT	Sagittarius Nov. 23 Sunrise 7H. 30M. Length of day 8H. 2M. NOV	Capricorn Dec. 23 Sunrise 8H. 46M. Shortest day 7H. 45M. DEC

Appendix III — Equation of Time values shown on dial

JAN 1 8 15 22 29 Dials slower than watches or 4 7 11 12 14	FEB 1 8 15 22 29 clocks 14 14 14 13 13	MAR 1 8 15 22 29 11 9 7 5 4
APR 1 8 15 22 29 X Dials 3 2 0 2 3	MAY 1 8 15 22 29 Fast 3 4 4 4 3	JUN 1 8 15 22 29 X Dials Slow 2 1 0 2 3
JUL 1 8 15 22 29 3 6 6 6 5	AUG 1 8 15 22 29 X 5 4 3 2 0	SEP 1 8 15 22 29 Dials Fast 0 2 5 7 11
OCT 1 8 15 22 29 11 12 14 15 16	NOV 1 8 15 22 29 16 16 15 14 11	DEC 1 8 15 22 29 X Slow 10 8 4 22 3

ACKNOWLEDGEMENTS

A special word of thanks to Silas Higgins of the National Museum of Ireland, Country Life, at Turlough, Castlebar, Co. Mayo, who went out of his way to make my visit enjoyable and worthwhile.

REFERENCES AND NOTES

1. P. Ransom: 'An Irish Dial', *Bull. BSS* 18(i) pp.23-25 (2006).
2. National Museum of Ireland. Sundial Ref. F1963:185.
Photographs are copyright and may not be reproduced without permission.

3. Tony Wood: see recent BSS Newsletters for details of the Museums Survey.
4. National Science Museum, St. Patrick's College, Maynooth, Ireland. Theodolite Ref. 371. Photograph is copyright and may not be reproduced without permission.

Author's address:
 1a Greenhaw Rd.
 LONDONDERRY
 N. Ireland, BT48 7RZ
 m.j.harley@ntlworld.com

BSS NEWBURY MEETING

22 September 2007

JOHN LESTER

The day at the Mary Hare School began on a sad note as Peter Ransom, chairman for the day, announced the recent death of Dr Margaret Stanier who had been Editor of the Bulletin from 1998 to 2006. John Foad then appealed for a volunteer to take on the job of Membership Secretary since he was about to relinquish this post in order to become the Society's Sundial Registrar.

The first speaker was John Davis who described two stained-glass sundials made by John Rowell - see page 179 of this issue for the full story.

Janet Jenkins then showed us how a substantial TV wall bracket, obtainable from B&Q, had been used to mount a heavy vertical sundial at a distance from a wall in order to escape the shadow of a drainpipe. The bracket was adjustable so that the correct orientation could easily and accurately be achieved.

Tony Wood explained to the mathematicians in the audience how he had found a mathematically rigorous proof of the formula which not only governed the behaviour of a Hooke's joint but was also that used to generate the hour lines on a vertical south dial.

Peter Ransom followed with a description of a programme for schools which would bring dialling into the curriculum and encourage pupils not to abandon the study of mathematics. There were many elements to this which included a 15 minute DVD, cut-out models of various types of sundial and even a set of 30 cards bearing pictures of sundials and information about them which would enable pupils to use them to play 'Top Trump'. The programme involved history, geography and IT elements and a teachers' information pack was available. The programme had undergone trials by a number of teachers in several schools and had proved to work successfully.

The afternoon session began with the pre-presentation by Chris Daniel of a replica Butterfield dial to Geoffrey Lane as his 2006 New Authors' Award for the best *Bulletin* article by a maiden contributor. Having made the presentation, the Society's Chairman then explained the workings of the universal equinoctial ring dial



which had been invented by William Oughtred. The antique brass example he passed around has been used at sea, most recently by Sir Robin Knox-Johnson.



Michael Maltin then described the construction and use of a much neglected instrument, the diploidscope. Invented in 1840 by Dent and Bloxham, it was capable of fixing the time of meridian passage of the sun with great accuracy by the coincidence of images produced by three reflecting surfaces and, once set up, gave greater precision than a noon mark.

'Investigating the Post' was the title of Jim Quinn's talk in which he described a dial with a vertical gnomon which was not at the focus of the hour lines. By altering this offset it could be adjusted for various latitudes and it was an improvement on the analemmatic dial since an allowance could be made for the height of a human gnomon.

A hemispherical dial which could be used at any latitude, in any orientation, and with its nodus in any position was the subject of the talk by David Booth. He had devised a sophisticated Excel spread-sheet which would enable makers to produce such a dial with any parameters they chose.

*continued on
page 155*

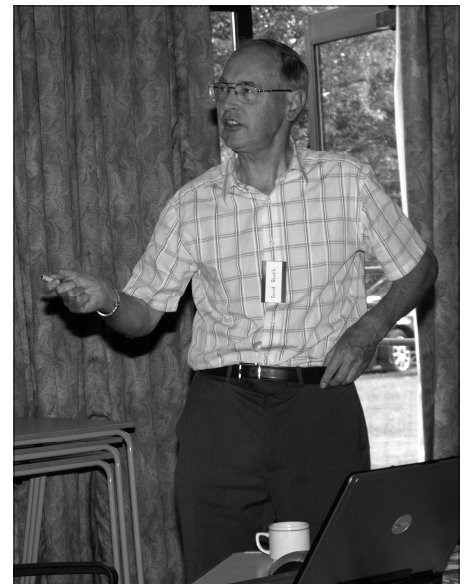

A STRANGE CREATURE

IAN R BUTSON

Many sundial enthusiasts will of course be familiar with the term ‘sciagraphy’, or the art of shading and shadows. It is also the art of finding the time by the shadow of a sundial. The word for shade, *skiagraphia*, comes from Ancient Greek. However, how many will be aware of the unique creature known as a SCIAPOD?

Within one of the finest churches in Suffolk, St Mary’s, Dennington (7 miles NW of Saxmundham) a mediaeval bench-end carries a carving of this unusual being – the only known example in an English church. This strange creature from the world of folklore rests under the shade of his own foot.



Fig. 1. The sciapod illustrated by Schedel.

An illustration from *Liber Chronicorum* by Hartmann Schedel, Nuremberg, (1493) and which describes “monstrous races from the edges of the Earth”, shows the sciapod at rest, sheltering from the sun beneath his on enormous foot (figure 1). The story of the sciapod goes back to antiquity. There is a reference in Pliny to the creature’s “great pertinacity” in leaping. Simon Jenkins also notes in his book *England’s Thousand Best Churches*¹ that “these most curious of ancient beasts were said to carry fruit at all times to smell, since they died if they breathed contaminated air”! The sciapod is also noted in several other books as detailed below.²⁻⁴

Figure 2 shows the sciapod carved into a bench-end (centre aisle, south side, sixth bench from the west). Interestingly, the Dennington sciapod is evidently carved largely from imagination for rather than the ‘correct’ if unlikely single foot, the carver has chosen to give him two.



Fig. 2. The sciapod on a Dennington church benchend.

Aside from the sciapod, the church is rich with treasures, with colour and elaborate carvings everywhere. One of its great glories is the set of mediaeval benches dating from the 15th century. They have carved backs and 76 intricately carved ends, all different, with poppy-heads and an intriguing array of armrests showing animals, birds and other creatures from mythology. These include a pelican with her young and a mermaid. Other treasures include a sandtable, used to teach children to read and write, a church chest carved out from a solid block of oak over 700 years ago, and elaborate parclose screens. Two of these screens enclose the restored tombs of Lord Bardolph (d.1441) who fought at Agincourt with Henry V, and his wife. For the sundiallists, there are even two mass dials to be found on a buttress by the south doorway (figure 3).



Fig. 3. Dennington’s two mass dials.

Perhaps those members of the BSS who seek out sundials could also loosely be described as sciapods, but with the wish that the sun might shine to illuminate their finds, if not their feet!

REFERENCES

1. S. Jenkins: *England’s Thousand Best Churches*, p.646, Penguin Press (1999).
2. A. Mee: *The King’s England: Suffolk*, pp.119-122, Hodder & Stoughton (1941).
3. A. Jobson: *Suffolk Villages*, p.110, Robert Hale & Co. (1971).
4. J. Timpson: *Timpson’s Country Churches*, p.86, Weidenfeld & Nicholson (1998).

Author’s address:
60, Churnwood Rd
Colchester, CO4 3EY

Ben Jones: letter carver, sculptor and sundial maker

A visit report by Douglas Bateman

Ben Jones is not yet widely known as a sundial maker, but what he has made are beautifully carved and artistically very attractive. A visit to Exeter gave me the opportunity to see Ben, have an exhilarating scramble over the roofs and parapets of Exeter Cathedral, and see some of his work first hand.

Ben's formal training was in the The City and Guilds of London Art School to study lettering followed by employment with a monumental mason, and then for 2½ years as a carver/mason for Exeter Cathedral. The work involved restoration on the Cathedral and other Devon churches. This was for a large variety of pinnacles and their ornamental crockets, 'grotesques' and even humble coping stones and door lintels.

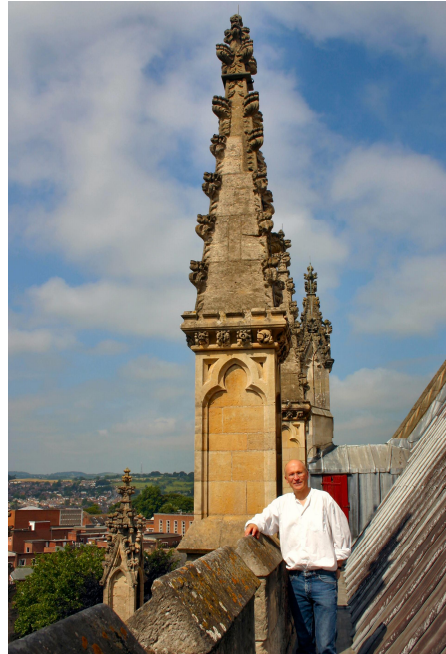

On the roof of Exeter Cathedral: over 50 pinnacles and other stonework provide stonemasons a lifetime's work of restoration.

Materials range from stone, slate and granite, to wood and brick. His reputation is such that he has done special lettering and a plaque for the nearby National Trust at Killerton, and a granite boulder and slate plaque as a gift from the county of Devon to the Queen, and panels of lettering for the Royal Devon and Exeter Hospital.

Ben's interest in sundials began quite early whilst at the art college, seeing them as means of carrying a variety of lettering and letter forms. He purchased a copy of *Sundials, their Theory and Construction* by A.E. Waugh, and was an early joiner of the Society although it was a while before he attended the annual conferences. Commercial work on sundials began when he decided to cease employment with the Cathedral stonemasons: dials currently comprise about 25 - 30% of his commissions.



A memorial on a rough block of slate with the lettering on the cleaved surface, with only the cherub delicately sculpted in relief

This shield shaped dial, although in stone, has a soft and tactile look.



The artistic influence is very strong and no two sundials are alike. A prime example is the shield form of vertical dial, a modest 56cm high, in white smoothly finished limestone contrasting the rough hewn surface between the hour markers.

A contrast is the strong rectangle (over page) with the lettering and dial in relief. I commented on the rather Teutonic style and Ben told me it was inspired by the book *Schrift + Symbol* by Sepp Jacob and Donatus Leicher. Diallists will be more familiar with similar lettering on dials illustrated in *Sonnenuhren* by Heinz Schumacher from the same publisher, Callwey.

Independence was felt to give better prospects so in 1989 Ben began to make memorials, plaques, signs and sundials to private commissions. Some of the commissions have followed from displaying his work at a number of local, county, and London art exhibitions.

With lettering as a professional skill Ben has been a full craft member of the Letter Exchange since 1994. More recently, in 2006 Ben shared a stand with Piers Nicholson at the Chelsea Flower Show.



Skilful lettering in rough Bath stone 40cm square. Photo: B. Jones.



*SUM SI SOL SIT
I am if the sun is.*

A most interesting sundial is the inclining/declining memorial dial at the Ottery St Mary hospital (SRN 5654). The dial plate is in Cumbrian green slate and the pedestal is Ham Hill stone.

A complete contrast is the small dial on top of tall multifaceted column. Such a dial will be quite striking when set against box hedges in a formal garden.



B. Jones

An imaginative design so that the dial can be easily seen from a path.



*"Zig Zag"
An abstract sculpture with a horizontal dial.*

B. Jones

Perhaps more traditionally, vertical dials in slate have been commissioned. In addition to completely new dials, the example illustrated is actually a copy of a dial that was stolen. With typical understatement, in Ben's words "It is another side to being a jobbing stone carver. And it was a real pleasure to carve such idiosyncratic numerals."

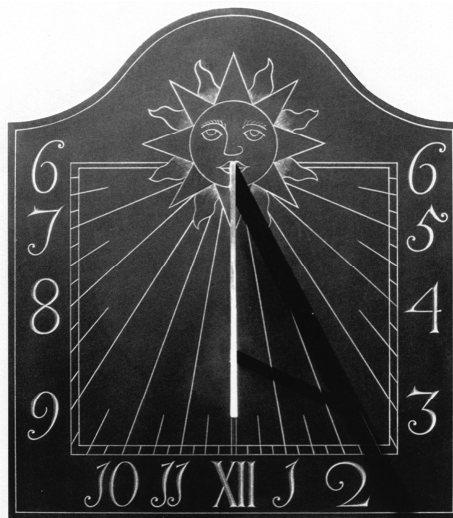

*A vertical dial in slate. Note the use of a Roman XII at noon mixed with the stylish Arabic numerals.
Photo: B. Jones.*

Ben has completed several analemmatic dials for customers of some note, including Blickling Hall (NT), Norfolk. The hour markers are in York stone and, unusually for this type of dial, an equation of time graph is provided and set into one of the hour markers (SRN 5839).



B. Jones

A polar dial in Portland stone with the motto ALBO LAPILLO NOTARE DIEM which means to mark your day with a white stone and bad days with a black stone or charcoal.

Another good example of the sculptural form is a double polar dial; rather like the 'Teutonic' dial, with lettering and hour lines in relief. It will be curious to see if the passage of time leaves the lettering more visible than the more easily carved incised lettering in stone, where the 'let down' lettering often fills with moss or lichens to reduce the contrast with the stone as a whole.



B. Jones

A tall pillar with mean time dials conveniently at eye height. A superb example of advanced dial design and craftsmanship.

This report is not complete without mentioning a Cumbrian slate pillar with four dials in a private garden in Devon. It is very similar to the one in the rose garden of the Royal Horticultural Society, Rosemoor, Great Torrington, North Devon. The dials give mean time and the plinth for the RHS dial has an appropriate inscription from a poem by T S Eliot "*But only in time can the moment in the rose garden be remembered*". Both were designed by our Patron, Sir Mark Lennox-Boyd.

Quite a lot of the work comes through Yellow Pages and his website www.benjonessundials.co.uk.

Links from the Society and other sites are becoming more beneficial too. Even so, the main source is word of mouth and connections with local craft organisations and past exhibitions.

To conclude on a personal note, Ben has a gentle manner, lives in a modest house with his wife Pru, (who is a professional archaeologist and looks after the calmly atmospheric garden), and has a small workshop in the Devon countryside. I believe this holistic approach is reflected in the artistic interpretations for customers leading to individually unique and flawless sundials.

NEWBURY 2007

continued from page 151

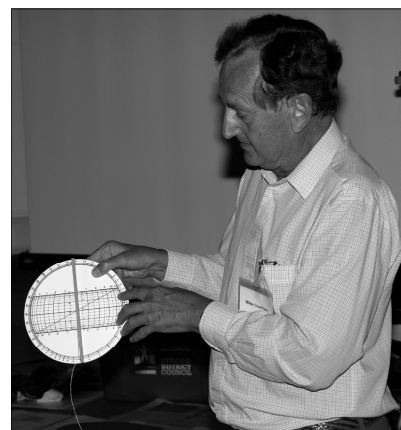

The talks ended with the showing by Peter Ransom of some pictures of the installation of a school memorial sundial.

It was now the turn of the exhibitors to explain their displays. Patrick Briggs had again brought some of his amazing Meccano devices. Getting the gearing right was the challenge, he told us, and he had clearly met this brilliantly with his Jovilabe, artificial satellite model, ellipsograph and analemma meccano-graph as well as others equally fascinating. Michael Maltin



supplemented his talk by giving a practical demonstration of the diplescope he had constructed. Mike Cowham demonstrated two unusual altitude dials by Rojas and Regiomontanus and the demonstrations ended when John Davis showed us Richard Delamain's horizontal quadrant and a McClintock helio-chronometer.

A very successful day for the 45 people who attended was brought to a close with a vote of thanks to David Pawley and Peter Ransom for their unfailingly efficient organisation of the meeting.



ASTROLABES

Part 3 – Arabic Astrolabes

TONY ASHMORE

INTRODUCTION

The Arabic peoples became heirs to much of the Ancient Greek learning and manuscripts. Accordingly, the early progress in astronomy and observation, including the early development of the astrolabe, took place in the areas surrounding, in today's terminology, the Persian Gulf. Many Greek works were translated into Arabic and were accompanied by the production of instruments, observation and notable original writings.

The spread of Islam eastwards as far as the Indian sub-continent and westwards along the North African territories and, eventually, much of Spain, carried this knowledge with it. Later Western contact with Moorish Spain and the consequent translation of the Arabic writings into Latin became the main channel by which this learning passed to the west.

In this extensive area 'arabic' instruments were produced during a period stretching from before the tenth century to the nineteenth century. In comparison, a much smaller area of Western Europe produced instruments largely from the thirteenth to the eighteenth centuries. These geographical and chronological factors account for much greater numbers of Eastern astrolabes being manufactured and surviving than of Western instruments.



Fig. 14. Late 9th century Syrian astrolabe.

GENERAL

Over this large area, from India to Spain, there are many variations in the styles of instruments produced but there are some basic variations to be found from those on Western astrolabes. The most obvious is the use of 'arabic' scripts, Fig. 14. These scripts, to most Westerners, may appear similar but they do vary both in time and geographical location but they are always clearly not any form of Latin script. As the knowledge and hand manufacture methods followed the spread of Islam it is natural that there is mostly a common thread in their overall appearance. These are mainly based on 'Persian' productions, especially those developed in the Isfahan region. In later, twentieth century, descriptive writings in English of these astrolabes authors tend to group them under general classifications based on area. Apart from Persian, those produced at the eastern end of the range are often classed as Indian. This description was applied well before the 1947 partition of the sub-continent. The ideas were taken there by the Mughal invaders or made there by accompanying Islamic artisans. However, a few are known which are superficially similar instruments produced by Hindu craftsmen, seemingly for Hindu clients and engraved in Sanskrit. Similarly, a very few Jewish astrolabes exist which are like Islamic instruments but engraved in Hebrew, recognised by the distinctive angular script. Instruments originating at the Western end of the Islamic conquests are usually referred to as Maghribi – the Maghreb being an ill-defined area of NW Africa, mainly Morocco and Algeria, sometimes extending as far east as Tunisia. Moorish, occasionally Hispano-Moorish, is used for those instruments from Islamic Spain. In whichever part of the Islamic world the astrolabes were made they tend to be much more individualistic in their detailed design than Western ones. One does not find common patterns used by several makers as, for example, the Flemish group mentioned in Part 2.

There are two aspects of Arabic astrolabes that can be regarded as virtually universal in these instruments. Firstly, until late in their period, mechanical time keeping devices were not in common use especially for travellers. Therefore, equal hours were of little interest, the norm being the traditional unequal hours as described in Part 2. So the two I – XII equal hour scales on the outer edge of the limb seen on Western astrolabes do not normally occur

and, consequentially, the rule on the front of the instrument to transfer the sun's position in the ecliptic to the outer edge is not needed and is very seldom included. Secondly, astrological phenomena were an extensive and extremely important part of daily activity. Scales relating to this aspect of life were included where possible, resulting in a very full and often cluttered appearance on the instruments, particularly on the back. This aspect will not be covered in these articles.

CHARACTERISTICS AND SCALES OF ARABIC INSTRUMENTS

As the front of an astrolabe, wherever it was made, has the same time-related function as Western instruments the main features are easily recognised, Fig. 14. The limb, as mentioned above, does not have the equal hour scales but includes each quarter divided into 90° starting on the horizontal axis. The rete, engraved with the signs of the zodiac, star pointers and the usual part of the Tropic of Capricorn, is unmistakable. The fixed plate underneath with the almucantars and unequal hour lines is essentially identical to the description on page 110 of Part 2. This is an example of an instrument having a rule provided.

Throne: Some texts in English use *kursi*, the Arabic name. In early instruments, say into the 14th century, the throne tends to be small with little decoration, as in Western examples, Fig. 14. This is not surprising since the Western versions were developed from the earliest Eastern products. In later instruments it becomes much bigger, triangular in shape but largely plain, Fig. 15, and later still appears beautifully decorated, frequently with intricate geometric patterns or interlaced calligraphy, following the artistry seen on and in buildings and books, Fig. 16. Anyone who

has visited the *Alhambra* in Spain, for example, will be familiar with the extensive use of pattern and lettering for decoration throughout those buildings. The calligraphy frequently contains inscriptions from the Koran and the maker's signature.

Rete: These similarly follow a progression in decoration to the throne. Fig.14 could be called utilitarian in showing minimal addition to that needed for purely functional use. The few star pointers are broad, dagger shaped and the Tropic of Capricorn circle is totally unadorned apart from three star names. Fig. 15 is particularly decorative with many more stars. At the top inside the ecliptic it, unusually, includes a little calligraphy and, in the centre the star Vega is indicated by a standing bird. This latter is not so unusual for Islamic astrolabes. The rete of Fig. 16 is less intricate but the ornate calligraphic work on the foliate-style pointers and the Capricorn arc, the shaping of the ecliptic circle and the treatment of the degree band on the limb all point to a high status astrolabe with fully mature, but restrained, artistic development.

Unlike Fig. 14, the last two plates show, as well as the unequal hour lines, additional arcs in the lower half relevant to astrological use. All three retes include a knob to rotate the rete. Sometimes there are multiple knobs provided for this purpose.

The ornamental wedge through the top of the pin holding together the plates, rete and, where included, the rule is referred to as the *horse* due to its outline shape. Fig. 17 shows an especially fine example as used in Fig.16.

Plates: These are similar to those found on Western astrolabes, having the same function. Arabic ones almost



Above: Fig. 17. Detail of the 'horse' of Fig. 16.

Far Left: Fig. 15. Persian astrolabe dated 1682.

Left: Fig. 16. Astrolabe of 1708/9 from Isfahan.

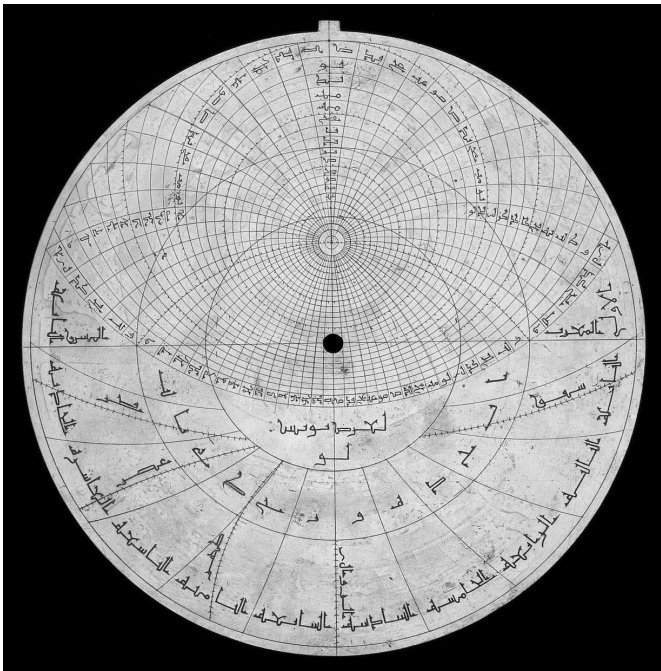

Fig. 18. Plate from a Moroccan astrolabe of 1733/4.

invariably have more labelling of the values of the almucantars and azimuths, everyone being numbered if the instrument is large enough. Fig. 18 is an example from Morocco dating from 1733/4. As well as the unequal hour lines in the lower part of the plate, this includes two lines to indicate the start and end times for afternoon prayers. These are the lines marked with cross ticks close to the end of the eighth hour and about the middle of the tenth hour (these hours being counted from the west horizon on the right, the sixth, noon, being to the right of the vertical meridian line).



Above left: Fig. 19. Gazetteer of Fig. 16.

Above right: Fig. 20. Back of Fig. 16.

Right: Fig. 22. Alidade of Fig. 16.

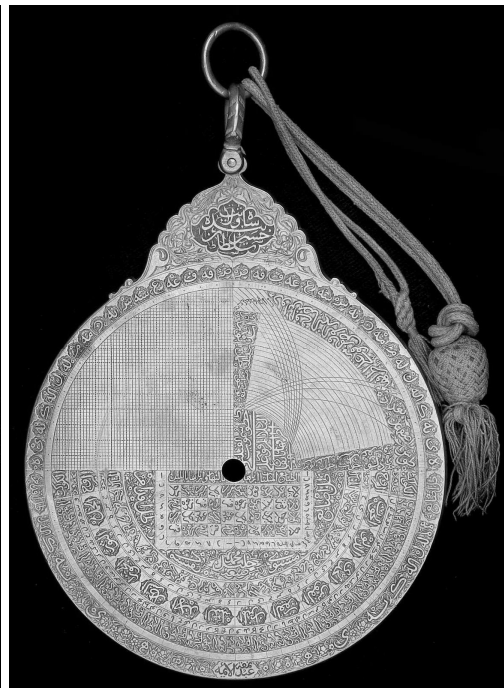

These prayer time indicators are frequently present. Much more unusual is the presence of the crepuscular line (see page 93, Part 1) which, in this case, is close to the end of astronomical twilight than civil twilight. Some plates on late astrolabes may have an excess of calligraphic ornamentation including completely filling the lunette between the horizon arc and the Tropic of Cancer.

Mater: This is the main part of the astrolabe. The depression in the centre of the mater, into which the plates and the rete fit, is called the *womb* – in Arabic the *umm*. The base of the womb of Arabic instruments is nearly always engraved, in a circular pattern, with a ‘Gazetteer’ having a similar function to the gazetteers in our ordinary atlases. In these astrolabes the gazetteer is a list of cities with their latitudes and longitudes, sometimes with additional geographical information such as the distance from Mecca. Fig. 19 illustrates the womb, with its gazetteer for 44 cities, of Fig. 16.

SCALES ON THE BACK

Fig. 20 shows the back of the instrument in Fig. 16 and is very much in keeping with the design and decoration on the front of this astrolabe. The scales are a mixture of indications with many of those in the lower half being astrological. The main non-astrological devices are described below.

Shadow Square: From the description given in Part 2 this should be easily recognised suspended from the middle of the horizontal diameter. Unlike Western instruments where

the two halves are mirror images of each other, Arabic astrolabes almost invariably have one half – normally the left – divided into 7 parts whilst the other is divided into 12. The corresponding degree scale for measuring angles is found on the upper half of the circular scale on the outer edge of the rim, divided from 0, from both ends of the horizontal, to 90° at the top below the *kursi*. Note that inside the numeral arc there is a narrow, plain band with dots every 5 degrees with, very faint, line divisions for each degree. Not found on Western instruments, the Arabic versions include a cotangent scale on most of the lower part of the outermost circular scale.

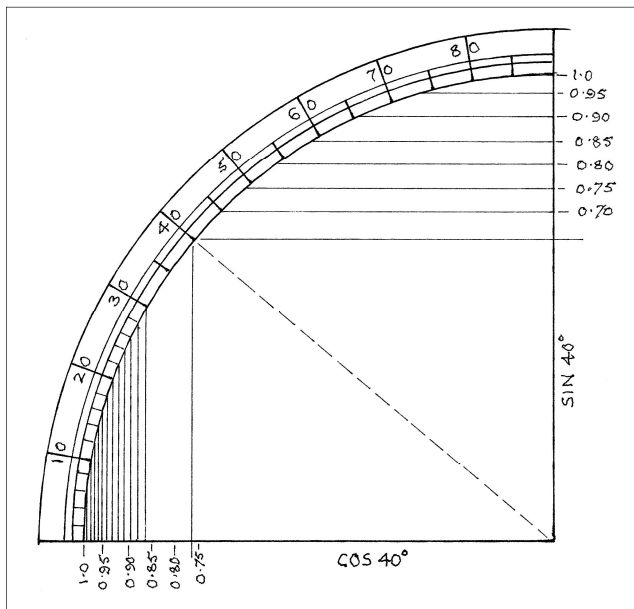

Fig. 21. The principle of the sine/cosine quadrant.

The lower end of the alidade gives the cotangent of the angle indicated by the top end of the alidade. Besides the surveying use of the shadow square, the cotangent scale together with the 7 and 12 divisions and the unequal hours on the plates can be used to determine when a vertical gnomon will cast a shadow of a given length. This is useful in, for example, the determination of prayer times. A 7 'foot' gnomon was often used but this 'foot' is not related to our foot measure. Also the 12 division refers to a 'fingers' measure but, again, has nothing to do with our fingers!

Sine/Cosine Grid: This usually occupies the upper left quadrant of the astrolabe back. It is used in conjunction with the alidade and the 0-90° scale outside it. Fig. 21 indicates the principle of its use. Due to the engraving for other functions being right up to the sine and cosine axes there is not room to engrave these trigonometric values on the back surface itself so the bevelled edge of the alidade, Fig. 22, is used to carry the scale. The grid itself may be engraved in either of two ways. As seen in the upper part of Fig. 21 the lines are evenly spaced which means that, in general, they do not coincide with exact degrees and the user has to interpolate the angle for a value read from the alidade. The alternative, favoured much less, is to draw the grid lines for whole degrees, as drawn at the left hand side of Fig. 21, but this means the sine lines become progressively closer as angles approach 90° and, likewise the cosine lines crowd together for angles closer to zero. We may imagine that trigonometric functions are relatively recent but Hipparchus in the 2nd century BC tabulated trigonometric ratios and Ptolemy extended and improved this work.

The Arcs of the Signs: These occupy the top right quadrant of the astrolabe back, the signs being those of the zodiac. In

themselves these arcs are not of much use but allow the display of two other scales. Fig. 23 and the following two sections provide an explanation of their use. The arcs, as they normally appear on the astrolabes, Fig. 20, and as drawn in Fig. 23, are the stereographic projection of the circles of the sun's declination. Since these circles lie between the Tropics of Cancer and Capricorn and are symmetrically divided either side of the celestial equator they appear the same whether projected from the south or north poles. Only the labelling is different for each pole. Projection from the south pole means the outer arc represents the Tropic of Capricorn and the inner the Tropic of Cancer. The sign sigils for this arrangement are those between 0 and 10°. Projection from the north pole means the inner arc represents the Tropic of Capricorn with the outer being for the Tropic of Cancer, the corresponding sigils being given between 80° and 90°. These sigils may be found in Ref. 1, Appendix 1. The variable spacing of the arcs is similar to the 'bunching up' of dates around the solstices on the analemmas of some noon marker sundials.

Midday Altitude of the Sun: This may be plotted for any given latitude for any day of the year. The arcs of the signs form a zodiac calendar so they, in conjunction with the degree scale on the outer edge, can be so used. The maker can refer to tabulated values of maximum altitude (or it may easily be calculated from $90^\circ - \text{latitude} + \text{declination}$, declination being negative between the autumnal and vernal equinoxes). For Aries 20 and latitude 40° N the midday altitude is (was since the real – not astrological – 'first point of Aries' and the obliquity of the ecliptic has changed over the centuries) $55\frac{1}{2}^\circ$. Plotted on the arcs gives point C. Similarly, for 50° N and Taurus 20 gives point D. Plotting points for other dates and any chosen latitude enables curves similar to those two drawn on Fig. 23 to be generated. Fig. 20 shows eight curves, at two degree

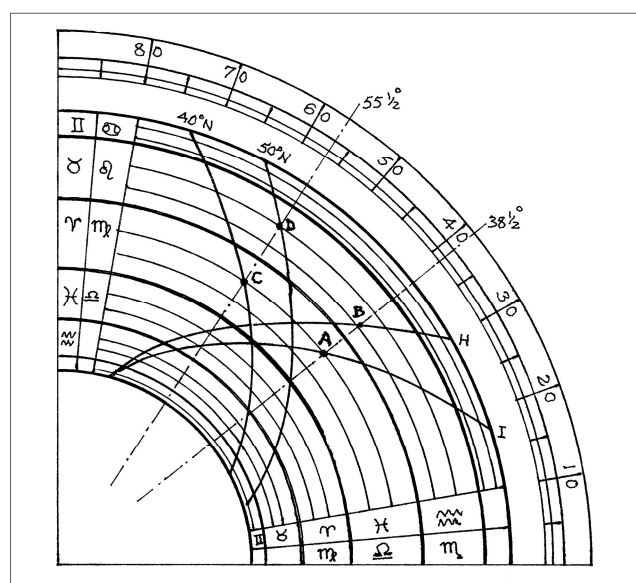

Fig. 23. The use of the arcs of the signs, midday altitude and Qibla.

intervals, covering the latitudes 28° to 42°. The sigils next to the vertical axis are the appropriate ones for these dates.

The midday altitude can be read directly off the front of the instrument but this will be only for the latitude of that plate. The scale on the arcs allows for any latitude within its range, more convenient and even if a plate for that latitude is not available.

Qibla: Occasionally with slight variation of spelling on translation of the Arabic into English. This is the name given to the direction of the Sacred Mosque at Mecca, which all Muslims are expected to face when at prayer. This is given by the other curved lines shown engraved on the Arcs of the Signs, each curve being for a designated city as labelled. The curve shows, for each day, the altitude of the sun when it is in the direction of Mecca. The sigils on the horizontal axis indicate the relevant dates for finding the Qibla. On Fig. 20 four Qibla curves are engraved, for Shiraz, Bagdad, Isfahan and Tus. On Fig. 23 curves for two cities have been drawn, H for Harran and I for Isfahan. At point A, on the zodiacal dates Pisces 10 and Libra 20, and point B, on the dates Aquarius 19 and Scorpio 11, facing the sun when its altitude is 38½° the user would be facing the direction of Mecca from Isfahan and Harran respectively. These Qibla are of more use if a traveller, say, was in the vicinity of the city rather than in it where the correct direction to face is indicated by the prayer-niche, or *mihrab*, in the Mosque.

Harran is in modern Turkey, just over the Syrian border. The inclusion of the Qibla for Harran on an appreciable

number of astrolabes is interesting in that Harran is almost due north of Mecca, being a little over 1000 miles north but only 52' west in longitude, say 48 miles at the latitude of Harran. This is reflected in the change of altitude for Harran in Fig. 23 which is about 44½° in my, probably a little inaccurate, drawing. For an exactly due south direction, the change in the sun's meridian altitude would be 47° from summer to winter solstice

The curves of the meridian altitudes and the Qibla are not circular arcs although they might look as though they are. Since the Arcs of the Signs are effectively only a grid on which to display the midday altitude and the Qibla it is not necessary that the stereographic projection is used for the arcs. On some instruments the arcs are drawn evenly spaced. As long as each arc can be clearly identified with the date it doesn't matter and this prevents the 'bunching up', making it easier to identify days close to the solstices. The resulting latitude and city lines are not simple arcs but become sigmoid (s-shaped) curves. The stereographic arcs are more usually preferred.

ACKNOWLEDGEMENTS

The photographs in this article are all reproduced with the kind permission of the Director of the Museum of the History of Science, Oxford.

The C V Boys dial in the Royal Botanic Garden, Kew

Members may like to know that the cross dial has been taken out of store and is now set up in the Mediterranean Garden, near King William's Temple. The dial was featured in some detail in the Bulletin by Doug Bateman: 'The Cross Dial by C V Boys at the Royal Botanic Gardens, Kew', *Bulletin* 17(iv) pp.172-5 Dec 2005.



Paul Shaw from Co. Antrim was the winner of the 2006 Photographic competition and is seen here with his prize of a polyhedral dial.

**Beautifully Crafted Replicas of Early
PORTABLE DIALS
at Affordable Prices**



Pillar Dial
standing 20cm tall
Order Code A212 - £19.99



**Mariners
Astrolabe**
Order Code H82
£17.00

Key Ring Instruments



Nocturnal
Order Code H83
£18.00

GREEN WITCH
www.green-witch.com
01954 211288
Unit 6, Dry Drayton Industries, Dry Drayton, Cambridge CB23 8AT

NEW DIALS

This is the first in a new occasional feature in the Bulletin aiming to showcase new dials.

Leicester University

Allan Mills' 'Eye of Time' noon mark at Leicester University has featured in the *Bulletin* before (issue 17(iv), p.175, December 2005). It was formally opened on 8 June 2007 by Lord (Richard) Attenborough, seen in the photograph with Allan (left) and Mrs Jean Humphreys who donated it to the University to commemorate her late husband, Professor Arthur Humphreys. The sculpture, standing 2 metres high, rests on the lawn outside The Attenborough Building, named after Lord Attenborough's father who was Principal of what was then the University College of Leicester.

The sculpture was carved from Portland stone by Fairhaven of Anglesea Abbey Ltd. It features a noon analemma indicating 12:00 o'clock GMT on the inner surface of the sculpture, which is in the style of Henry Moore and Barbara Hepworth.



Leicester University Press Office

Westminster School

Westminster School backs onto Westminster Abbey and has a long and illustrious history—one of its old boys was Robert Hooke. This new sundial was designed as a memorial to Adolph and Freda Prag and was dedicated on 27 June 2007 which would have been Adolph Prag's 101st

birthday. He had escaped to England just before World War II and taught mathematics at the school from 1946 to 1966. He was also the School Librarian (organising a fine historical collection) and a noted authority on the history of mathematics, particularly on the work of Isaac Newton. His wife Freda was also very active at the school.

The sundial project was initiated by the Prags' three sons, John, Peter and Thomas, who were all pupils at the school, with contributions from former pupils. (These included the ex-Chancellor Nigel Lawson. Now, I wonder if we could get Gordon Brown to contribute to a dial project...?)





The opening of the dial coincided with Tony Blair's last day in office. As a result, it was accompanied by helicopters hovering over Westminster and a large police and press presence just outside the haven of the school quad.

The dial was designed and made by BSS member Harriet James. It is carved in Portland stone to match Westminster Abbey just behind it and it has an elliptical chapter ring which alludes to Newton's diagrams of planetary orbits. The nodus is in the form of a gold-plated sphere after early design ideas of using a glass prism were unsuccessful. The centre declination line is for the equinoxes as standard but the lower and upper ones are not for the solstices but for 27 June and 23 November, Adolf's and Freda's birthdays respectively. This is explained on a bronze plaque, which includes an equation of time graph, on the wall below the dial.

The dial is set into the wall with random quoins in Bath stone around it to match the nearby windows. Stonemason Mark Rawlins did this work and also devised the method of cutting the gilded scaphes in the corners of the dial.

Okatjorute Farm, Namibia

This newly-completed dial is thought to be unique in several ways, being the first double horizontal dial for the southern hemisphere, and within the Tropic of Capricorn as well (latitude $21^{\circ} 55' S$; longitude $16^{\circ} 47' E$). It was made by Malcolm Barnfield, who also made the noon cannon seen in the September issue, with technical assistance from James E Morrison, the American astrolabe enthusiast. It is in stainless steel and is 390mm across the flats. The vertical knife-edge gnomon used on normal double horizontal dials is replaced here by a thin vertical rod, leaving the cen-

tral region of the gnomon to its north hollow. This allows the shadow to be seen on the stereographic projection after the sun transits the latitude each December 1st and then staying to the south of the vertical gnomon until the following January. For just a few days around the transit, this part of the dial cannot be read directly as the shadow is too short. To help in this situation, an associated instrument with an altitude alidade is mounted to the south side of the main dial (so that it does not shadow it) where it rotates around a vertical axis to follow the sun's azimuth.

Notice that the declination curves closest to Cancer have the opposite direction of curvature to the rest of the grid and very large radii – over 200 metres – which were just within the range of Corel Draw. This complicated the calculations for the ecliptic lines which incorporate two extra spots for the birthdays of the clients (coloured red for Mars and green for Venus!).

For historical reasons, Namibia's Civil Time is GMT+2 hours, rather than the GMT+1 hour which its longitude would indicate. This accounts for the large longitude correction of 52 mins 52 secs given on the dial. Because of this, Namibia now uses Daylight Saving Time during winter.

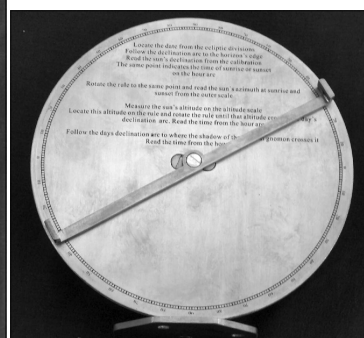
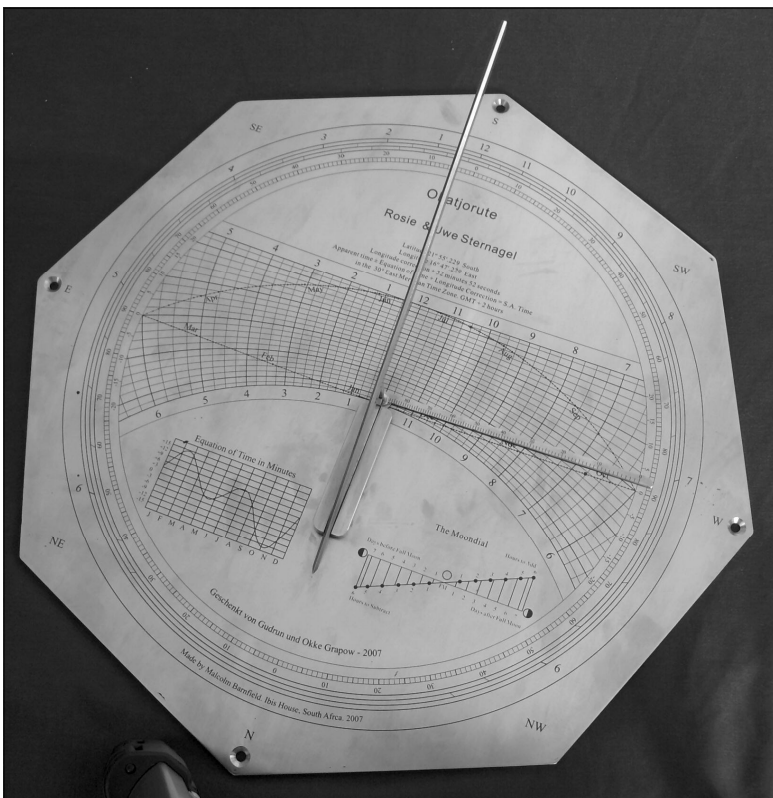

See www.sundials.co.za for more details.

Macclesfield - a (very) late Saxon sundial

This very late Saxon dial is the memorial stone for my dog and now stands in my garden in Macclesfield. I carved it myself from a hard local sandstone coping stone, 100×36×8 cm. The dial, date and the inscription, which translated reads 'The best dog, always', is framed by her collar. I could have done it in Saxon, but then nobody would have had the pleasure of working it out. Her name, Ishtar, the Babylonian goddess of love and war, was chosen by my daughter who studied middle eastern archaeology. The lettering I selected from an old *Letraset* catalogue as being bold without deep cutting, and the motif at the base is two intertwined tails in Celtic plait fashion. Delineation is by use of the diagrams in Allan Mills' article, 'Seasonal Hour Sundials for the British Isles', *Bull BSS*, 90 (3), 15-21 (1990).

Well, we all do strange things sometimes.

Roger Bowling

Pollagh, Co. Galway, Eire

This large (16 metre diameter) dial is claimed to be the largest of its type in Ireland and has recently been installed at Brigit's Garden. The Garden is open to the public during the summer and is just a 20 minute drive north of Galway city, 2km from the N59 between Moycullen and Oughterard (Lat 53° 23' North, Long 9° 15' West). The gnomon is made from a 1.75 metre piece of bog oak and the dial has fifteen declination lines, one for the first day of each month, two for the solstices and one for the equinoxes. These are colour coded for the two halves of the year and there are two separate notices telling visitors how to read the dial during each period. The months are labelled around the outside of the dial. The hour lines (not clearly visible in the photographs) are in the form of analemmas.

The site features four separate gardens, one for each of the old Celtic festivals. The start of the Celtic year is the festival of Samhain on 31 October (equivalent to the modern Haloween). The Spring festival of Imbolc, on 1 February, is

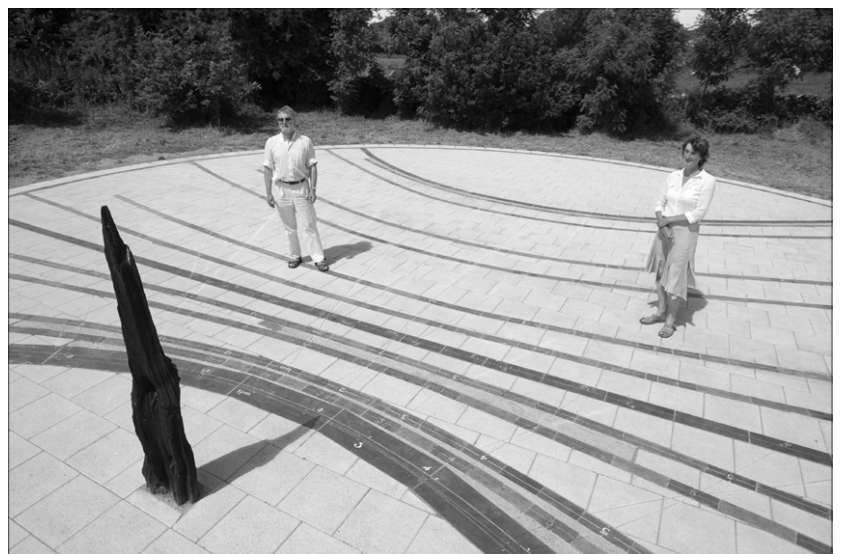

Joe Shaughnessy



Joe Shaughnessy

now St Brigit's Day. Bealtaine, for the start of Summer, can be equated to May Day and the final festival is Lughnasa in early August.

The design and construction team included Jenny Beale, founder of Brigit's Garden. Her husband Dr Colin Brown of NUI (National University of Ireland) Galway was the designer; Máire Ní Chionna was the site engineer, Mick Wilkins was the stone carver, Ronnie Graham was responsible for the bog oak gnomon, and Mick Lynch and Micheil Lynch laid the stone.

For more information see the Brigit's Garden's website <http://www.brigitsgarden.ie>.

Michael Harley

THE METHOD OF EQUAL ALTITUDES OR THE INDIAN CIRCLE

HUGH McCAGUE

INTRODUCTION

This article describes the method of equal altitudes, also known as the Indian Circle, and its ancient and medieval references in both Western and Eastern cultures. This method for the determination of the meridian and the four cardinal directions was mentioned in various historic texts on astronomy, practical geometry, architecture, land surveying and town planning. This simple and efficient procedure involved the observation of a gnomon's shadow at two crucial times during the morning and afternoon. This practical method shows the importance of gnomonics in the history of architecture, town planning and cosmology. The method of equal altitudes was a central part of the extensive work that was done with vertical gnomons, in various epochs and cultures, pertaining to various characteristics and measurements of the shadow: its length, direction over the course of a day and a year, and especially with regard to the determination of the meridian and the equinoxes and solstices.

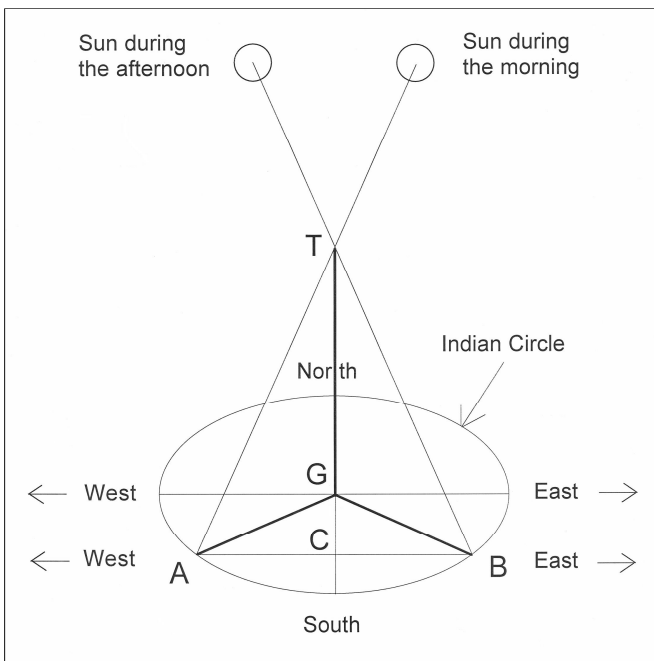

Fig. 1. The determination of the meridian line and the four cardinal directions by observing two shadows of equal length cast on a horizontal surface by a vertical gnomon rod during the morning and the afternoon. This method is known as the method of equal altitudes or the Indian Circle. (The circle, literally the Indian Circle, centred on the gnomon's base at G, is not drawn to perspective.) Image drawn after Yano, p.18 fig.1 in ref.16.

First, we will review this method and then proceed with an historical survey. The method of equal altitudes is commonly known and described in elementary books on land surveying or geomatics,¹ and introductory books on sundials.^{2,3} Albert E. Waugh gives a good description of this method as one of the common ways to find the meridian and lay out the noon mark.⁴ The basic method (Fig. 1), with minor variations, can be described as follows:

- 1) prepare a horizontal surface,
- 2) erect a vertical gnomon rod (TG) in the central area of the surface,
- 3) describe a circle⁵ centred on the gnomon's base at G,
- 4) during the morning, as the sun's shadow cast by the gnomon shortens, observe when the tip or apex of this shadow touches (before it enters) the circle during the morning, and mark this point A,
- 5) similarly, during the afternoon, as the sun's shadow lengthens observe when the apex of the sun's shadow again touches (before it exits) the circle, and mark this point B, and
- 6) bisect the line segment BA at C and join CG: CG is a meridian line perpendicular to BA, the E-W line.

The direction from C to G may be S-N or N-S, or C and G may be co-incident (Fig. 2), depending on the latitude, time of year and time of the morning when the initial observation of the shadow is made. In each individual case, this determination of N-S can

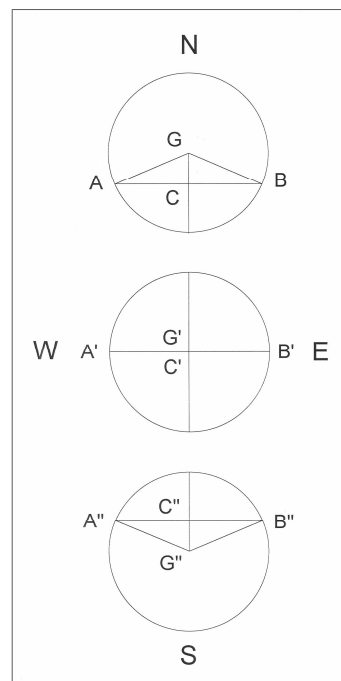

Fig. 2. The method of equal altitudes: possible locations of the line segment BA (indicating E-W) and its midpoint C with respect to the base of the gnomon at G: (top) BA to the south of the gnomon at G, (middle) B'A' coincident at C' with the gnomon's base at G and (bottom) B''A'' to the north of the gnomon at G''.

be made in reference to BA, the E-W line. Step 6 is equivalent to constructing the perpendicular bisector of the line segment BA at C and then G is deemed to lie on this perpendicular. Also, Step 6 is equivalent to bisecting $\angle BGA$. The equal length of the two observed shadows ($GA = GB$ equal to the radius of the Indian Circle) cast on the horizontal surface from the vertical gnomon with a fixed height implies that the sun had the same altitude during both observations ($\angle TAG = \angle TBG$). This insight is the reason for the procedure's name: 'method of equal altitudes'. While this method is simple and practical, it has beneath the surface many issues of note pertaining to a) errors and approximations, b) the characterization of the shadow curve, and c) historical architectural design and cosmology.

ERRORS AND MATHEMATICAL ANALYSIS

First, various minor to negligible errors can arise in the implementation of this method. For example, due care must be taken to erect a gnomon rod to true vertical on a leveled horizontal surface with well-defined circular arcs accurately

centred on the base of the gnomon. Also, the determination of the apex of the shadows can, of course, be subject to some error. Additionally, even more technical, as Waugh⁶ notes, the sun's declination is changing slightly from the times of the observations taken in the morning and the afternoon. This slight change means that the symmetry assumed about the meridian line by this method is not strictly correct. Taking measurements around the times of the solstices when the solar declination is changing at a minimal rate can reduce this small error even further.⁷ However, the predominant errors arise in laying out the instrument and taking the observations, so care in these matters alone provided sufficiently accurate results for historic applications. Indeed, with care, the meridian can be determined within approximately $\pm 30'$. While this method is not considered sufficiently accurate and efficient by modern professional surveyors, they still consider the procedure of educational value in their textbooks.⁸ The accuracy of this method can be moderately increased by taking several observations in

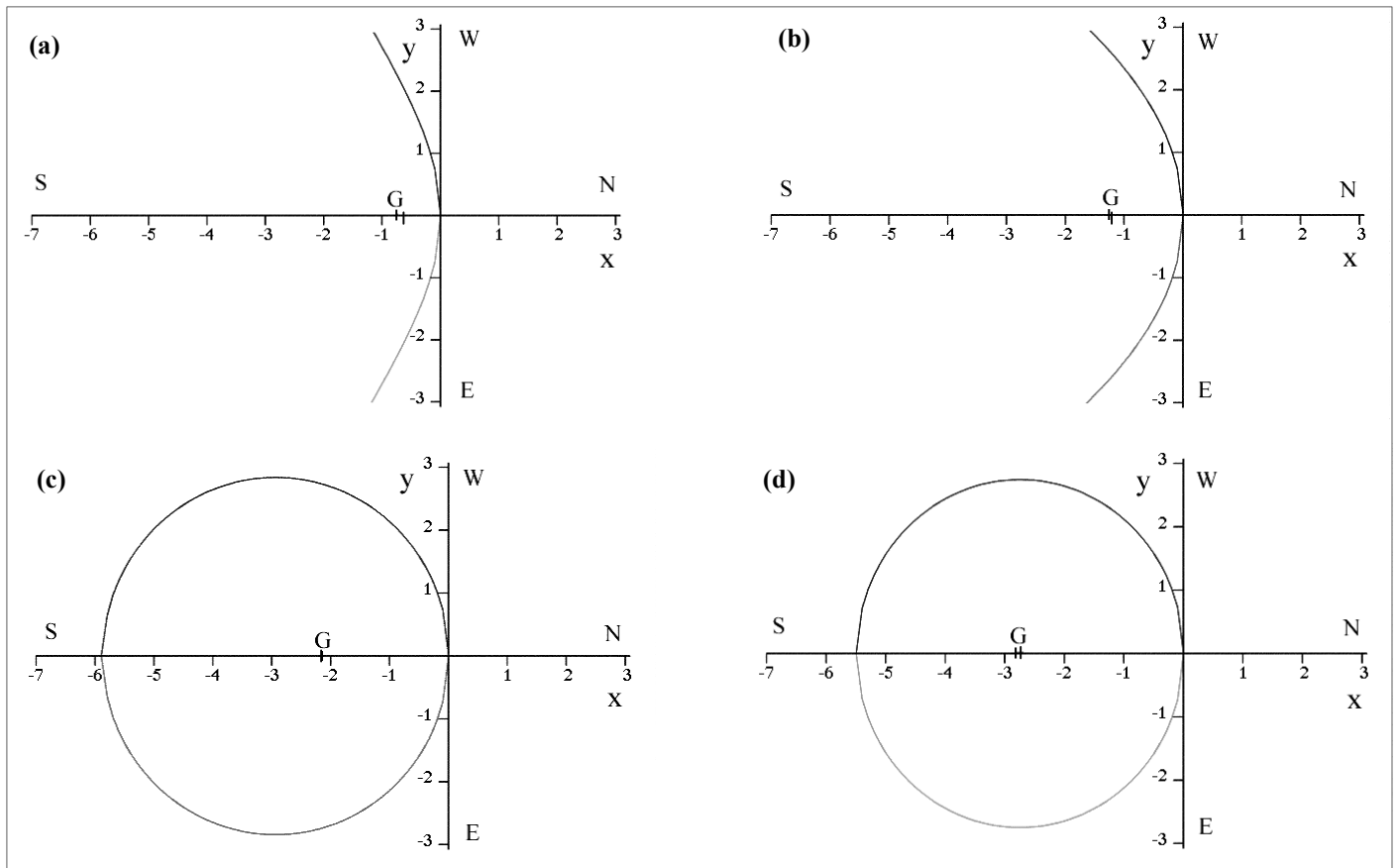

Fig. 3. Shadow curves described by the tip or apex of a shadow cast on a horizontal surface by a vertical gnomon with its base at G. The origin (0,0) point occurs at solar noon. The unit of measurement on the X and Y axes is the vertical height of the gnomon rod above the horizontal surface (TG in Fig. 1).

(a) A hyperbola occurring at latitude $\phi = 55^\circ N$ with solar declination $\delta = 20^\circ$ (and co-declination $p = 70^\circ$ which is greater than the latitude). The shadow curve is only the section of the hyperbola that occurs on the S side of G (i.e.,

the non-positive side of the Y axis).

(b) A parabola occurring at latitude $\phi = 70^\circ N$ with solar declination $\delta = 20^\circ$ (and co-declination $p = 70^\circ$ equal to the latitude).

(c) An ellipse occurring at latitude $\phi = 85^\circ N$ with solar declination $\delta = 20^\circ$ (and co-declination $p = 70^\circ$ which is less than the latitude).

(d) A circle at latitude $\phi = 90^\circ N$ (i.e., the North Pole) with solar declination $\delta = 20^\circ$ (and co-declination $p = 70^\circ$ which is less than the latitude).

the morning, and the corresponding observations can be taken in the afternoon. The resulting estimated N-S lines can then be ‘averaged’ for an even more confident estimate.⁹ These extra observations also have the advantage of increasing the probability that clouds will not obscure the sun for at least one pair of crucial observation points.

Strikingly, if the sun’s declination is assumed constant during the course of a day, the path of the tip or apex of the shadow over the course of that day is a conic section based on the latitude and sun’s declination.¹⁰ As noted already, this assumption of constant declination is, of course, not correct, but the errors involved are very small. The resulting shadow curve equation, for those days and locations where the sun rises, is:

$$Y^2 = -2(\tan p)X - \left(1 - \frac{\cos^2 \varphi}{\cos^2 p}\right)X^2, \quad p \neq \pm 90^\circ$$

where φ is the latitude and p is the polar distance or co-declination of the sun. Note $p = 90^\circ - \delta$ for $\delta \geq 0^\circ$ and $p = -90^\circ - \delta$ for $\delta < 0^\circ$, where δ is the sun’s declination.¹¹ The X-Y co-ordinate system is set such that the origin (0,0) is at the apex of the sun’s shadow at noon, a point that lies on the meridian line extending from the gnomon’s base. The X-axis extends positively to the north, and the Y-axis extends positively to the west.¹² The sign of the second order term on x (i.e., the x^2 term) determines the type of conic section. If the magnitude of the latitude is less than the magnitude of the co-declination, the curve is a hyperbola (Fig. 3a). If the magnitude of latitude is equal to the magnitude of co-declination, the curve is a parabola (because the second order term on x vanishes) (Fig. 3b). If the magnitude of the latitude is greater than the magnitude of the co-declination, the curve is an ellipse¹³ (Fig. 3c) which includes the special case of the circle (i.e., an ellipse with eccentricity of 0). The circle occurs when the coefficient on x^2 is unity. Hence, $\cos^2 \varphi = 0$, so the latitude is $\pm 90^\circ$, i.e., the North and South Poles when the sun is rising at those locations (Fig. 3d). A shadow curve that is an ellipse, including the special case of the circle, has the dramatic implication that the sun, while above the horizon, neither set nor rose on that day.

In regard to the relatively small inaccuracy of this method, John McKim Malville notes:¹⁴

Swinging between its winter and southern extremes at the solstices, the sun moves most rapidly at the equinoxes. At the time of vernal equinox, for example, since the sun moves northward between midmorning and mid-afternoon, the Eastern point [B in Fig. 1], produced by the afternoon shadow is shifted slightly southward of the Western point [A in Fig. 1]. The line connecting the two points [AB in Fig. 1] would thus be tilted south of east in the spring and north of east in the fall.

The correction, due to the slight change in the sun’s declination, is given by:

$$s = h(\sin \delta_1 - \sin \delta_2) / \cos \varphi, \quad \varphi \neq \pm 90^\circ$$

where s is the (perpendicular) distance from the apex (B in Fig. 1) of the afternoon shadow to the E-W line, h is the length of the hypotenuse formed by the apex of the gnomon to the apex of the morning shadow (TA in Fig. 1), and δ_1 and δ_2 are the sun’s declination at the morning and afternoon observations, respectively. φ is the latitude as above.^{15,16} The declination completes one cycle each year from approximately -23.5° at the winter solstice to 0° at the spring equinox to approximately 23.5° at the summer solstice to 0° at the vernal equinox and then back again to approximately -23.5° at the winter solstice.^{17,18} For the small correction formulae above, the point B would need to be translated (moved) $|s|$ units due S, if s is negative. Similarly, B would be translated s units due N, if s is positive. However, note that the change in the declination during the six hours from mid-morning to mid-afternoon reaches a maximum absolute value of only approximately $6'$ (at the time of the equinoxes).¹⁹ Thus, in general, $|s|$ will be very small, unless $\cos \varphi$ is close to 0 (i.e., φ is close to $\pm 90^\circ$ at the North and South Poles), and so the tilt of the BA will be very little off E-W.

HISTORICAL SURVEY: EAST AND WEST

The method of equal altitudes is described in a variety of important and influential manuscripts from the ancient and medieval periods in both Eastern and Western cultures. The method is often given without an explanation as to why it works. This absence of explanation is commonplace in the practical, as opposed to theoretical, texts of antiquity where procedures are emphasized more than proofs or technical justifications.

Roman surveying manuals, the *Corpus Agrimenorum*, copied through the Middle Ages give procedures for the orientation of sites for rectangular systems of fields and streets laid out along E-W and N-S axes²⁰ and variations thereof. The method of equal altitudes was employed by the Roman land surveyors, *agrimensores*, for site orientation. *De munitioibus castrorum* (c.100 AD), a Roman treatise on making military camps by Pseudo-Hyginus Gromaticus, describes this method for determining the four cardinal points and their axes:^{21,22}

First we shall draw a circle on a flat space on the ground, and in its centre we shall place a sundial gnomon, whose shadow may at times fall inside the circle as well as outside. ... When the shadow reaches the circle, we shall note the point on the circumference, and similarly when it leaves the circle. Having marked the two points on the circumference, we shall draw a

straight line through them and bisect it. Through this we shall plot out *kardo*, and *decumani* at right angles to it.

Note that this method is explicitly in the context of sundialing. *Kardo* and *decumanus* are technical terms of Roman land surveying and refer to certain perpendicular axes in the plane of a surveyed field. Here, *kardo* is a surveyed line, usually N-S. *Decumani* is a surveyed line perpendicular to the *kardo*, usually E-W.²³ The term *kardo* means ‘hinge’ and refers to a pole or axis, so its is fittingly associated with a N-S line and the celestial axis.²⁴ Indeed, the method of equal altitudes is based on the apparent movement of the sun about the celestial (N-S) axis through the earth. This method would determine the *kardo maximus* and *decumanus maximus*, the crucial major perpendicular axes of Roman land surveying, intersecting (at C in Fig. 1) beside where the gnomon had been erected (at G in Fig. 1).

Of further note, Pseudo-Hyginus Gromaticus, in emphasizing the value of the method of equal altitudes, points out in regard to some Roman land surveyors:²⁵

Many ignorant of cosmology, have followed the sun’s rising and setting. ... After positioning the *groma* under correct auspices, when the founder [of a colony] himself might be present, they have taken bearings from sunrise as accurately as possible. But then their *kardo* does not tally with the sixth hour.

Again, from the reference to the “sixth hour” we see the close relationship between sundials and correct surveying alignments. The *groma* was a standard Roman surveying instrument (Fig. 4). The time from sunrise to sunset each day was divided into twelve equal hours. (The length of an hour would, of course, vary from day to day as the time from sunrise to sunset varied over the year.) The sixth hour is midday or noon²⁶ and hence the time when the sun’s

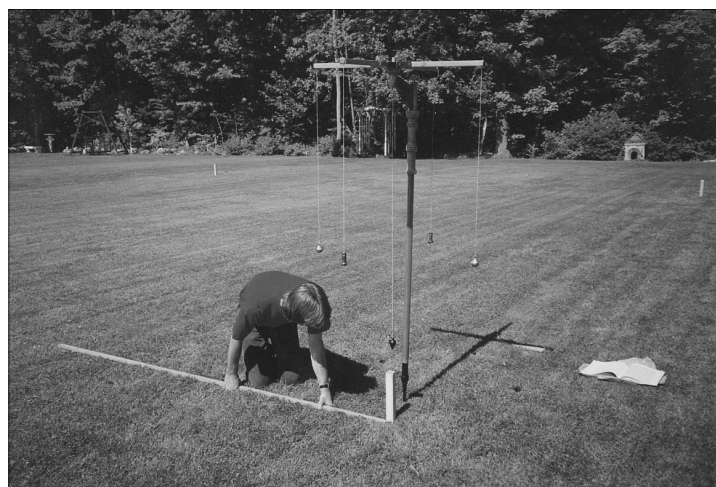

Fig. 4. A reconstruction of the Roman *groma* surveying instrument. Surmounted on the central pole is a swivelling cross-piece with four plumb-lines for sighting a pair of lines at right angles. The method of equal altitudes was a way to align these lines with the four cardinal directions.

shadow was on the meridian. Also, in general, the method of equal altitudes was easier to implement than the observation of the sunrise and sunset positions. This ease is due to the former not requiring an unobstructed horizon and it is less affected by intermittent sunshine.

The main extant Roman architectural treatise, *De Architectura* (c. 29-22 B.C.) by Vitruvius, also mentions essentially the same method for orienting town streets. Later in the text, Vitruvius discusses the eastern orientation of temples, but gives no procedure for its implementation.²⁷ It is extremely likely that the procedure was the very same method he described earlier for town plans.

One of the most learned ecclesiastics of the early Middle Ages, the Benedictine monk the Venerable Bede (c.673–735) also gives this method in his ‘*Libellus de Mensura Horologii*’,²⁸ a description of sundials and *horologia*. The *Geometria incerti auctoris*, a 10th or 11th century text on practical geometry, metrology and surveying with extant 11th century copies,²⁹ gives this method³⁰ where it is drawn from the Roman *Corpus Agrimensorum*.³¹ The learned Augustinian canon Hugh of St. Victor (1096-1141) mentions this method in the chapter on “Altimetry,” dealing with terrestrial and celestial surveying, in his *Artis Cuiuslibet Consummatio*, a text on practical geometry. Hugh mentions that this method “is necessary to all astronomers everywhere”,³² though given his text’s use of the *Corpus Agrimensorum*, he would have appreciated this method’s value to terrestrial surveying as well.

For a gnomon, the shortest shadow points north and occurs at noon. The Roman author Pliny the Elder (23-79 AD), in advising farmers on the layout of their fields in his *Naturalis Historica*, notes this point for the determination of the meridian.³³ Also, Hugh of St. Victor shows knowledge of this point.³⁴ However, it would not be as practical nor as accurate in practice as the method of equal altitudes involving two shadows³⁵⁻³⁷ due to the reliance on a single measurement (per day) and the challenges of ‘capturing’ the minimal shadow at just the right time. The one-shadow method can be viewed as a collapsed case of the method of two shadows. In other words, if one took the observation of the first shadow closer and closer to noon (i.e., closer and closer to the end of the morning), one would correspondingly be obliged to take the observation of the second shadow closer and closer to noon (i.e., closer and closer to the beginning of the afternoon). In the limit, in the mathematical sense, both the first and second observations would converge as one identical observation at noon. Significantly, as Hugh of St. Victor concludes his exposition of the method of equal altitudes, he notes that the bisecting line segment (CG in Fig. 1) is the meridian line because the shortest shadow occurs there.³⁸

In Asia, the method of equal altitudes was employed widely in ancient, medieval and later periods.³⁹ In India, it was employed by Hindus, Jains and Buddhists for aligning, and setting the boundaries of, town plans, temples and other works of architecture with the four cardinal points.^{40,41} The Indian building manuals, the *Silpasastras*, such as the *Man-sara*, VI and the *Mayamata*, VI.1-10 describe this method as a ritualized procedure.⁴² Also, the *Katyayana-Sulbasutra* gives this method using a pole (gnomon) and cords in the context of constructing altars with sacred precincts.⁴³ The *Sisyadhivrdhida*⁴⁴ also mentions this method. Recommended heights for the gnomon and the radius of the (Indian) circle were given. Also notable, Indian astronomy applied some technical sophistication in deriving various corrections⁴⁵ for the method of equal altitudes including the correction formulae, $s = h(\sin\delta_1 - \sin\delta_2)/\cos\phi$, mentioned earlier. The value of that latter correction, known by 864,⁴⁶ is more in its insight into the inner workings and reasonable validity of the method of equal altitudes, rather than a practical attempt to implement this very small correction which requires accurate values of the two very close co-declinations, δ_1 and δ_2 . However, the Indian texts also instruct quite practically that, as noted earlier, the estimate of the meridian can be generally improved by taking more than one pair of observations and ‘averaging’ the result.⁴⁷

Indian knowledge of the method of equal altitudes was also passed to medieval Arab culture. The renowned astronomer and mathematician Al-Battani (858–929) mentions this procedure.⁴⁸ The illustrious mathematician and scholar Al-Biruni (c.978–c.1048) does likewise.⁴⁹⁻⁵¹ Indeed, this method was known as the ‘Indian Circle’ in the Arab world⁵² who thereby recognized its transmission from India.

The method of equal altitudes, and a closely related method involving the sunrise and sunset directions were employed in ancient China and later for architectural and city planning.⁵³⁻⁵⁵ Liu Dun points out that in the *Determination of Cardinal Directions*, attributed to Rong-Cheng, the method of equal altitudes is given.⁵⁶ It appears that this method may have arisen independently in ancient India and China because it predates the first known cultural exchange between these two countries.^{57,58} The computational classic the *Zhou bi* (or *Chou Pei* or *The Gnomon of the Zhou* [dynasty])⁵⁹ describes the determination of the meridian based on the observation of the directions of sunrise and sunset on a given day.⁶⁰ The *Zhou li* (*Chou-Li* or *Ritual of Zhou*),⁶¹ one of the classic Confucian texts from the 2nd century BC, does likewise.⁶² The *Zhou bi* also mentions that a horizontal surface for observing the sun’s shadow is made using a water-level.⁶³ Further, the *Zhou bi* states:⁶⁴

The method says:



Fig. 5. The two-pole method for marking sunrise and sunset positions on an unobstructed horizon. The *Zhou bi* (*Chou Pei*) describes the use of this method to determine the meridian halfway between the directions of sunrise and sunset. Pliny the Elder in his *Naturalis Historica* (II.69) mentioned this method in regard to the determination of the equinoxes. Sunset observation taken 13 May 1993 at Saugatuck by Lake Michigan, Michigan, United States, latitude $\phi \approx 42^\circ 40' N$.

Fix it by setting up the true [shadow] base.

When the sun first rises, set up the gnomon and note its shadow.

When the sun sets, note the shadow again.

The line between the two ends fixes east and west, and if one splits [the distance]

between them in the middle and points to the gnomon it fixes south and north.

The angle between the sunrise and sunset directions is, in effect, bisected in order to determine the meridian. As the sun rises or sets, its shadow is indefinitely long, so unlike the closely related Indian Circle method, the observer must sight the sun’s position with the gnomon and an additional aligned vertical rod (Fig. 5). Thus, in a partial and essential sense, this method is an extreme case of the method of equal altitudes because it involves observing the sun’s direction (but not the shadow length) at the two extremes, the very beginning and the very end of the day when the sun has equal altitudes of 0° . The *Zhou bi* also includes a detailed discussion of the gnomon and shadow lengths.^{65,66}

AN IMPLEMENTATION

In addition to the implementation of the method on a horizontal board or paved surface, a cleared and levelled surface of dirt or sand can be employed. The Venerable Bede appears to have employed such an instrument and layout on his monastic grounds at Jarrow and/or Monkwearmouth for

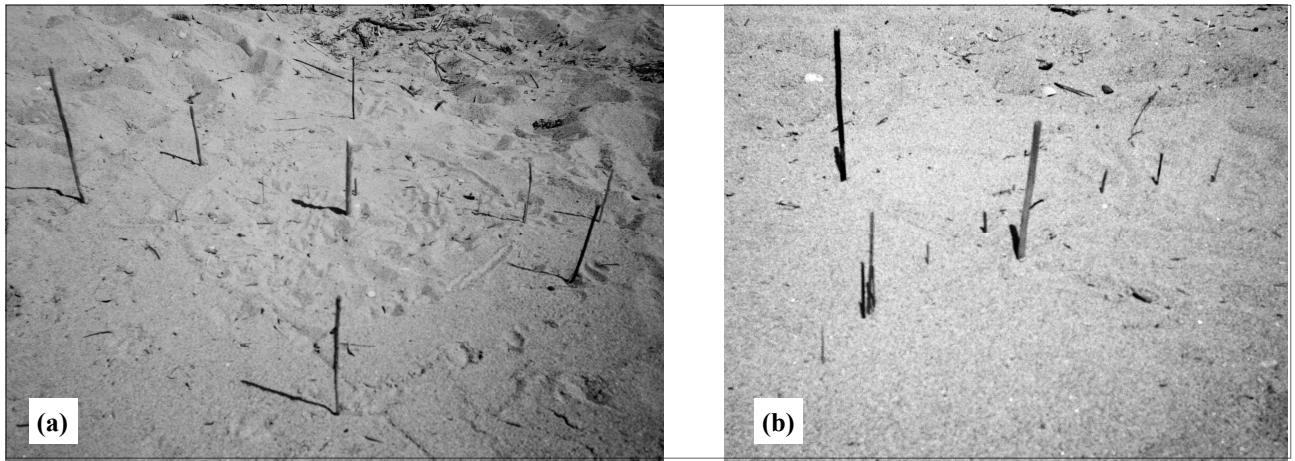

Fig. 6. An example of an exercise using the method of equal altitudes. On a sandy beach shore with lots of tree sticks washed ashore, nature provides right at hand most of the equipment for a rough and ready tryout of this method of determining the meridian. The tall central stick is the gnomon. Observations taken c.7 June 1992 at Southampton by Lake Huron, Ontario, Canada, latitude $\phi \approx 44^{\circ}30' N$. Photo taken the next day.

(a) The completion of the method of equal altitudes with smaller sticks marking corresponding morning and

afternoon observations. The larger sticks in the centre, lower centre, far right and upper centre mark the gnomon, S, W, and N, respectively. The larger stick in the upper mid-left (just to the right of the stick marking W) marks the direction to sunset.

(b) The smaller sticks mark the shadow curve over the course of a day. In this case, the curve is part of a hyperbola. The gnomon (the larger central stick) to the outer larger stick (upper left) marks the meridian.

his research and his students' edification.⁶⁷ Figure 6(a–b) illustrates how on a sandy beach shore with lots of tree sticks washed ashore, nature provides right at hand most of the equipment for a rough and ready tryout of this method of determining the meridian. The gnomon can be made by a larger reasonably straight stick erected in the sand. The gnomon can be made vertical and the working surface can be made horizontal with a spirit level. Alternatively, to check the vertical, a makeshift plumb-line can be made from string (or fishing line washed ashore) and a tied stone. More roughly, a flat stick can be used to horizontally smooth the sandy surface, and then stand well back and walk around the gnomon in order to check its verticality by eye. Positions of the apex of the shadow can be marked by smaller sticks. The Indian Circle and the bisection of the line segment can be carried out using some string (or fishing line) attached to a stick in order to simulate the operations of a geometric compass. In this manner, sticks can be erected in the four cardinal directions. Also, smaller sticks can be placed at regular intervals over the course of the day to illustrate the shadow curve. If the horizon is unobstructed, or the sun is rising or setting over a large lake or sea, the observer can lie down in the sand, and erect a stick that aligns with the gnomon and the rising or setting sun. In this manner, a diagram consisting of humble looking sticks in the sand is created in 'real time' and gradually takes on a fascinating and highly meaningful ordered form over the course of a day.

HISTORICAL SACRED AND COSMOLOGICAL ASPECTS: EAST AND WEST

Indeed, the diagram generated by the method of equal altitudes has a mandala-like quality that is deeply satisfying, ancient in heritage, and profound in its microcosmic correspondence to traditional cosmological structures of the universe. In order to elaborate on this point, we will consider the historical sacred and cosmological context of the method of equal altitudes.

An early basic structure for the ritualistic founding of towns was given in the liturgical books of Etruria and Latina, the *disciplina Etrusca*. First, the site was selected (*inauguratio*) through augury. Next, the site's boundaries were fixed (*limitatio*). The axes were laid out (*orientatio*) by observing the cast shadow from a vertical pole or gnomon set at the site's centre. Lastly, the consecration rite (*consecratio*) was performed to bring the city under the gods' protection.⁶⁸ Roman land surveying and its augural rituals appear to have been, at least in part, derived from the Etruscans.^{69,70} The Roman, Pliny the Elder refers to a small circle drawn at the base of a gnomon (a person standing upright) in a field as an *umbilicus* or navel.⁷¹ This *umbilicus terrae* was likened "to the Navel of the Earth, the primary centre of the earth, the place of initial centre"⁷² from which the corresponding act of surveying the fields would commence. The method of equal altitudes determined the cross of the four cardinal directions. This cross was used to align the horizontal cross-piece of the Roman *groma* for surveying the land. In this manner, the cross of the heavenly *templum*, said to have descended beforehand during the Roman

augural ritual, was manifested on earth. The augur would inwardly see the *templum* descend from the sky and heavens to form, and make sacred and habitable, the selected site or area. This preparation was deemed necessary to commence the surveying of the land.^{73,74} The augur's vision of the *templum* on high, the *templum* of the sky, is paralleled, in the Judaic and Christian traditions, by Ezekiel's vision of the measuring the Temple of Solomon (Ezekiel 40), and St. John of Patmos's vision of the measuring and descent of the Heavenly Jerusalem (Revelation 21). All three of these heavenly structures are aligned with the four cardinal directions and provide the earthly template. The method of equal altitudes allowed the builder to set the earthly template.

In aggregate, due east (E), or close to due east, appears to be the general mode, median and 'mean' for the orientation of medieval churches.⁷⁵⁻⁷⁷ However, one hastens to add that, within this overall view, individual churches often had their alignments off from E attributable, at least in large part, to the adaptation to pre-existing architectural, urban and topographical features in the landscape. The persons charged with implementing church orientation would have been the master craftsmen, particularly stonemasons. Their methods, passed through the apprentice system and working tradition, would largely derive from, and be similar to, the earlier methods of the Romans as represented by Vitruvius's *De Architectura* and the *Corpus Agrimensorum*. In this manner, the method of equal altitudes is not the only, but the most likely, procedure applied when a due east orientation was intended. In complement with the stonemasons, we noted earlier that the influential medieval teachers, the Venerable Bede and Hugh of St. Victor, wrote about this method. St. Isidore (c.570–636), in his widespread and standard encyclopedia of Middle Ages the *Etymologiae*, states:⁷⁸

A place, he [Isidore] says, designed so as to face East was called *templum* from contemplating. Of which there were four parts; the front facing the East, the back the West, the right hand the South, and the left hand the North: whence also when they builded temples, they took their East at the Equinox (*orientem spectabant aequinoctialem*), so that lines drawn from East to West would make the sections of the sky on the right and left hands equal, in order that he who prayed might look at the direct East.

Further to St. Isidore's observation, the orientation of churches had various iconographic identifications and liturgical purposes during the medieval period.⁷⁹ They include, but are not limited to, the identification with Christ as the sun rising eastward and Paradise in the East, the directing of prayer eastward, the moderation of the Church symbolized by the equinox, and the overall alignment of the cruci-

form church with the four quarters of the world.⁸⁰ The method of equal altitudes, by orienting the church to due east, also orients the church to the equinoctial sunrise position. In this manner, this method is a most practical and efficient method for achieving these geographic, sacred iconographic and liturgical requirements.

In the Hindu, Jain and Buddhist traditions, the method of equal altitudes was conducted as part of a ritual for the laying out of mandalas, altars, temples and towns or cities. The gnomon corresponded to the central celestial axis about which the cosmos was said to revolve. Hence, it was deemed necessary for not only the meridian line to pass through the base of the gnomon (Figs. 1 & 2), but also the E-W line, in order for the temple to be properly centred on the gnomon. Thus, some methods that modify the steps given at the beginning of this article were employed in order to ensure the coincidence of the gnomon's base with the E-W line. These careful acts were intended to re-enact the creation of the Cosmos, and defined and made sacred the surveyed space as a microcosm of the macrocosm.^{81,82}

In ancient and medieval Chinese and Confucian traditions, the method of equal altitudes, and the closely related method involving the directions of sunrise and sunset, were also part of the ritualized laying out of a city. The oriented design following cardinal axiality was based on a cosmic pattern. The steadfast emperor ruling from the capital city's centre, similar to the fixed gnomon, was likened to the celestial axis about which the heavenly realm revolved.⁸³

These metaphysical ways of thinking were central to these earlier theocentric and ritualized contexts for the pervasive method of equal altitudes. They show how profoundly meaningful gnomonics was in the history of architecture and culture, and still is today. Indeed, it seems that the deeper meaning of, and fascination with, sundials and gnomonics, including the Indian Circle method, arises when the inner order of the observer/sundialist, the order of the diagram and sundial, and the order of the universe/Creation once again match and harmonize.

REFERENCES AND NOTES

1. P.R. Wolf and C.D. Ghilani: *Elementary Surveying: An Introduction to Geomatics*. 10th edition. Prentice Hall, Upper Saddle River, New Jersey, 506-508 (2002).
2. R.R.J. Rohr: *Sundials: History, Theory, and Practice*. Trans. G. Godin. University of Toronto Press, Toronto and Buffalo, 33, 34 fig.25 (1970). Rohr mentions that the shadow curve is a hyperbola which is commonly, but not necessarily, the case as we will see later in this article.
3. M. Lennox-Boyd: *Sundials: History, Art, People, Science*. Frances Lincoln, London, 10 (2005).
4. A. E. Waugh: *Sundials: Their Theory and Construction*. Dover, New York, 19-20, 19 Fig.3.1 (1973).
5. The term 'Indian Circle' refers literally to this circle, as well as this method for determining the meridian.
6. Waugh, p.20 fn.1 in ref.4.
7. Waugh, p.20 fn.1 in ref.4.

8. An assessment of this method for modern surveyors appears in Wolf and Ghilani, p.507 in ref.1.
9. Waugh, p.20 fn.1 in ref.4.
10. H. Dörrie: *100 Great Problems of Elementary Mathematics: Their History and Solution*. Trans. from the German by David Antin. Dover, New York, 340-342 (1965).
11. Dörrie, pp.340-342 in ref.10.
12. Dörrie, pp.341-342 in ref.10 had the X-axis extend positively in the S direction, so no minus sign appears in the first order term of x . In the formula listed in this article, I changed the X-axis to extend positively to the north in order to keep the XY axes closer to the conventional layout of the four cardinal directions. One can, of course, arrange the X and Y axes differently with respect to the four cardinal directions, and the constants on x , x^2 , y and y^2 will change accordingly, but the family of curves being described remains the same.
13. Dörrie, pp.340-342 in ref.10.
14. J.M. Malville: 'Cosmogony and the Elements: The Intuition of Cosmos in Science and Myth' in *Man in Nature*, edited by Baidyanath Saraswati. Indira Gandhi National Centre for the Arts, New Delhi, (1995). Available on the web at http://www.ignca.nic.in/ps_05005.htm (accessed 16 August 2007).
15. Malville in ref.14.
16. cf. M. Yano: 'Knowledge of Astronomy in Sanskrit Texts of Architecture (Orientation Methods in the *Isanasivagurudeva-paddhati*)', *Indo-Iranian Journal*, **29**, 19-20 (1986).
17. Detailed data for part of this cycle during 2007 appears in F. Vincent: 'Solar Data 2007'. *Bull BSS* **18.4**, 185 (2006).
18. Detailed data for another part of this cycle during 2007 appears in F. Vincent: 'Solar and Lunar Data'. *Bull BSS* **19.3**, 134 (2007).
19. Malville in ref.14.
20. P.D.A. Harvey: *Medieval Maps*. British Library, London, 10-11 (1991).
21. O.A.W. Dilke: *The Roman Land Surveyors: An Introduction to the Agrimensores*. David and Charles, Newton Abbot, Devon, 57-58 (1971).
22. O.A.W. Dilke: 'Illustrations from Roman surveyors' manuals', *Imago Mundi*, **XXI**, 9-29, particularly 17 (1967). Figs.2d-2e reproduce two illustrations based on this quote that appear in medieval copies of the *Corpus Agrimensorum*. Fig.2e is misleading as noted by Dilke.
23. Dilke, pp.86-88, 215 in ref.21.
24. Dilke, pp.87-88, 231 in ref.21. As Dilke notes on p.87: in practice, the directions of the *kardo* and *decumanus* can sometimes vary from N-S and E-W axes, respectively.
25. Dilke, p.57 in ref.21.
26. Dilke, p.57 in ref.21.
27. Vitruvius: *Vitruvius: Ten Books of Architecture*. trans. by I.D. Rowland (translator); T.N. Howe (commentary and illustrations); I.D. Rowland and M.J. Dewar (additional material). Cambridge University Press, Cambridge and New York, I.6.6-7, IV.V.1, IV.IX (1999).
28. Bede: 'Libellus de Mensura Horologii' in *Bedæ Presbyteri. Patrologiae Latinae*, Tomus 90. J. P. Migne, Paris, (1850). Reprint: Brepols, Turnhout, Belgium, col.951-956, particularly col.953-954 (1980).
29. L.R. Shelby: 'The Geometrical Knowledge of Mediaeval Master Masons'. *Speculum*, **XLVII**, 395-421, particularly 400-401 fn.17 (1972).
30. N. Bubnov (ed.): *Gerberti postea Silvestri II papae Opera Mathematica (972-1002)*. Reprint of Berlin, 1899. Georg Olms, Hildesheim, 310-316, 363.5-364.9, 366, fig.101 (1963).
31. S.K. Victor (editor and translator): *Practical Geometry in the High Middle Ages, Artis Cuiuslibet Consummatio and the Pratique de Geometrie*. Memoirs of the American Philosophical Society 134. American Philosophical Society, Philadelphia, 227 fn.9 (1979).
32. Hugh of St. Victor, *Artis Cuiuslibet Consummatio*, II.3, pp.226-227, fig.41 in ref.31.
33. Pliny: *Natural History*. Latin with English translation. H. Rackham (editor and translator). William Heinemann, London and Harvard University Press, Cambridge, XVIII.326-329 (1971).
34. Hugh of St. Victor, *Artis Cuiuslibet Consummatio*, II.3-4, pp.226-229 in ref.31.
35. Dilke, p.17 in ref.22. Dilke also mentions a less practical method using three shadows fig.2f, pp.17-18 where Pseudo-Hyginus Gromaticus is quoted and a proof is given in solid geometry.
36. Didorus of Alexandria (before the 1st century B.C.), *Analemma* has a section on the determination of the meridian line using three shadows, and later medieval Arab scholarship also expounds on this method, as discussed by O. Neugebauer: *A History of Ancient Mathematical Astronomy*. 3 vols. Springer-Verlag, Berlin and New York, 841-842, 1376-1377 figs.17-19 (1975).
37. An approximate method involving three shadows was also known in medieval India, as discussed by Yano, pp.21-22 in ref.16.
38. Hugh of St. Victor, *Artis Cuiuslibet Consummatio*, II.3, fig.41, pp.226-227 in ref.31.
39. A. Snodgrass: *The Symbolism of the Stupa*. Southeast Asia Program, Cornell University, Ithaca, NY, 14 fn.3 (1985 and 1988).
40. Snodgrass, pp.14-17 in ref.39.
41. A. Snodgrass: *Architecture, Time and Eternity: Studies in the Stellar and Temporal Symbolism of Traditional Buildings*. 2 vols. Aditya Prakashan, New Delhi, 128-130 (1990).
42. Snodgrass, p.14 fn.1 in ref.39.
43. S.N. Sen and A.K. Bag: *The Sulbasutras of Baudhayana, Apastamba, Katyayana and Manava, with Text, English Translation and Commentary*. Indian National Science Academy, New Delhi, 120 1, 1.2 (1983).
44. B.V. Subbarayappa and K.V. Sarma (editors): *Indian astronomy: a source-book*. Nehru Centre, Mumbai (formerly Bombay), 182 4.1 (c.1985).
45. Yano, pp.19-20, 28 fn.9 in ref.16.
46. Yano, p.20 in ref.16.
47. M. Yano: 'Knowledge of Astronomy in Sanskrit Texts of Architecture (Orientation Methods in the *Isanasivagurudeva-paddhati*)', *Indo-Iranian Journal*, **29**, 17-29, especially 28 fn.9 (1986).
48. Al-Battini (M. J. Battani): *Al-Battini sive Albatanii Opus astronomicum*. C. A. Nallino (editor). 3 vols. Mediolani Insubrum, Prostat apud U. Hoeplium, vol.1, 24.1-46 (1899-1907).
49. Al-Buruni (Abu'l-Rayham Muhammad ibn Ahmad al-Buruni): *The Book of Instruction in the Elements of the Art of Astrology*. Trans. R.R. Wright. Luzac, London, par.131 (1934).
50. Al-Buruni (Abu'l-Rayham Muhammad ibn Ahmad al-Buruni): *The Exhaustive Treatise on Shadows*. 2 vols. E.S. Kennedy (translator and commentary). Institute for the History of Arabic Science, University of Aleppo, Aleppo, vol.1, 150, vol.2, 80 (1976).
51. E.S. Kennedy: 'Al-Bīrūnī's Maqālid 'Ilm Al-Hay'a', *Journal of Near Eastern Studies*, **30.4**, 308-314, particularly 313 (1971).
52. Victor, p.227 fn.9 in ref.31.
53. L. Dun: 'The Determination of Cardinal Directions Attributed to Rong-Cheng and the "Indian Circle Method."', *Sinology [Taiwan]*, **17.1**, 13-32 (1999). Available on the web at <http://www.ihns.ac.cn/members/liu/doc/indiamethod.htm> (accessed 16 August 2007). The main text is in Chinese.
54. P. Wheatley: *The Pivot of the Four Quarter: A Preliminary Enquiry into the Origins and Character of the Ancient Chinese City*. Aldine, Chicago, 461-462 (1971).
55. J.F. Meyers: *The Dragons of Tiananmen: Beijing as a Sacred City*. University of South Carolina Press, Columbia, South Carolina, 10-11 (1991).
56. Dun in ref.53.
57. Dun in ref.53.
58. L. Dun: 'A Discussion on the Literary Sources of the Method for Determining Cardinal Directions in Ancient China'. Website of the Institute for the History of Natural Science, Chinese Academy of Sciences, Beijing. Available on the web at <http://www.ihns.ac.cn/members/liud/doc/maoshi.htm> (accessed 16 August 2007).

59. C. Cullen: *Astronomy and mathematics in ancient China: the Zhou bi suan jing*. Cambridge University Press, Cambridge, xi, xi fn.1, 179 #B15 (1995). This text with 'gnomon' right in the title is the main extant document of ancient Chinese science, more specifically astronomy and mathematics. It was probably compiled in the 1st century BC, but it was traditionally claimed to have been written one millennium earlier.
60. J. Needham with the research assistance of Wang Ling: *Science and Civilisation in China*. Cambridge University Press, Cambridge, vol.3, p.21 (1954 -).
61. C. Cullen: *Astronomy and mathematics in ancient China: the Zhou bi suan jing*. Cambridge University Press, Cambridge, 172 (1995).
62. *Zhou li*, B, fol.15 recto et verso in Wheatley, 426, 462 n.47 in ref.54.
63. Needham, vol.3, p.21 in ref.60.
64. Trans. in Cullen, p.192 #F6 in ref.61.
65. Trans. in Cullens in ref.60.
66. Needham, vol.3, pp.284-294 in ref.60.
67. W.M. Stevens: 'Astronomy in Carolingian Schools' in *Charlemagne and his Heritage: 1200 Years of Civilization and Science in Europe*. Brepols, Turnhout, Belgium, 417-487, particularly 429-436 (1997).
68. Snodgrass, p.238 in ref.41.
69. O.A.W. Dilke: 'Varro and the Origins of Centuration' in *Atti del Congresso di Studi Varroniani*. Centro di studi varroniani, Rieti, Italy, II, 353-358 (1976).
70. O.A.W. Dilke: 'Religious Mystique in the Training of Agrimensores' in *Res Sacrae: Homages à Henri Le Bonniec*. D. Porte and J.-P. Néraudeau (editors). Latomus, Revue d'Études Latines, Brussels, 158-159 (1988).
71. Pliny, XVIII.LXXVI.326-329 in ref.33.
72. J. M. Lundquist: *The Temple: Meeting Place of Heaven and Earth*. Thames and Hudson, London, 9 (1993).
73. J. Rykwert: *The Idea of a Town: The Anthropology of Urban Form in Rome, Italy and the Ancient World*. Princeton University Press, Princeton, 45ff (1976).
74. P. Godfrey and D. Hemsoll: 'The Pantheon: temple or rotunda?' in *Pagan Gods and Shrines of the Roman Empire*. Monograph No. 8. Oxford University Committee for Archaeology, Oxford, 195-209, especially 200-201 (1986).
75. cf. J.R. Ali and P. Cunich: 'The Orientation of Churches: Some New Evidence', *Antiquaries Journal*, **81**, 155-193 (2001).
76. cf. P.G. Hoare and C.S. Sweet: 'The orientation of early medieval churches in England', *Journal of Historical Geography*, **26.2**, 162-173 (2000).
77. cf. I. Hinton: 'Church Alignment: Towards Patronal Saint Sunrise?', *Bull BSS* **18.3**, 132-136, especially 136 fig.6 (2006).
78. Isidore, *Etymologiarvm Sive Originvm*, XV.IV.7, translated in Bishop William Durandus: *The Symbolism of Churches and Church Ornaments*. Translation of the First Book of *Rationale Divinorum Officiorum*. J.M. Neale and B. Webb (translators and editors). Reprint of 1843 edition. AMS Press, New York, 216 (1973).
79. For example, over eight reasons for the orientation of churches to due east are given by Bishop William Durandus (c.1237-1296). Durandus, V.II.57, I.I.8 in ref. 78.
80. R. Gem: 'Towards an Iconography of Anglo-Saxon Architecture', *Journal of the Warburg and Courtauld Institutes*, **46**, 1-18, especially 12-13 (1983).
81. Snodgrass, 128-130 in ref. 41.
82. Snodgrass, 14-17 in ref. 39.
83. Meyers, 10-11 in ref. 55.

Author's address:
235 Calumet College
York University
4700 Keele Street
Toronto, Ontario M3J 1P3
Canada
hmccague@yorku.ca

CLOCK EPHEMERA AND SUNDIALS

The connection between watches or clocks and sundials is a very long standing one—see the front cover of this issue for an example. The London firm of J.W. Benson Ltd has issued many catalogues and is, perhaps, best known for the c.1882 *Turret Clocks* one. The picture has previously appeared on the back cover of *Bulletin* 98.1. Is that the churchwarden taking the time in preparation for setting the church clock? The image is widely known as the logo of the National Association of Watch and Clock Collectors Inc in North America. Perhaps they were influenced by the gnomon angle on the dial which looks more suited to New York than London!

Another image of a horizontal sundial is found on the cover of Benson's c.1935 catalogue for *Wristlet Watches*. This seems

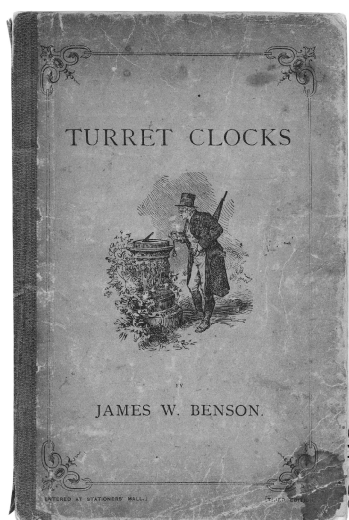

to show a drawing, rather than photograph, of an elegant contemporary dial. It has a noon gap but is clearly not illuminated by sunlight, judging by the splay of the shadow. The most interesting feature is the gnomon which is neatly truncated at its 'toe' so that it does not reach the origin. In doing so, it naturally forms a nodus but there are no lines on the dial-face using it. Is this a real dial or an artistic creation? It would certainly make a good model for a modern reproduction.

Images courtesy of the David Penney Horological Ephemera Library.

JD

READERS' LETTERS

Lambert circles and Seasonal Markers

In his article 'Sunrise and sunset hours on a garden analemmatic sundial' (BSS *Bulletin* June 2007, pp. 78-81) K.H. Head summarizes the sunrise/sunset markers invented by Roger Bailey (NASS Compendium Sept. 2003, pp. 1-7). He calculates their accuracy for his own latitude, 51.33°, corroborating the error analysis performed by Roger. The 'Bailey points' provide linear approximations of the Lambert circles, which are exact indicators of the times of sunrise/sunset. Mr Head considers Lambert circles "only of theoretical interest", which in my opinion implies an unjustified disdain for 'the real stuff'. In brief, a circle drawn through the two foci of the elliptical ring of hour points and a point on the date line intersects with the ellipse at the times of sunrise and sunset on that particular date. The most elegant proof I know has been published by Mr Willy Leenders in *Zonnetijdingen* (Bulletin of the Flanders Sundial Society) 2003 nr. 4, pp. 9-10.



Lambert circles have actually been included in analemmatic dials. If he has the opportunity, Mr Head should visit the beautiful analemmatic dial in Ootmarsum (The Netherlands), designed and constructed by Mr Bote Holman. Laid into the cement floor are seven Lambert circles, for the beginnings of the zodiacal months, which all cross the focal points (see photos). The dial has several additional features which are worth studying. See my website www.fransmaes.nl/sundials and choose Ootmarsum, Oostwal from the Index, for details.

*Frans W. Maes
Peize, The Netherlands
f.w.maes@rug.nl*

I was pleased to see the article by K. Head in the June 2007 BSS *Bulletin* acquainting BSS members with 'Sunrise and Sunset Hours on a Garden Analemmatic Sundial'. Seasonal Markers allow you to see when and where the sun rises and sets. They are a useful addition to any analemmatic sundial. Nothing in this world is perfect, except perhaps Lambert's Circles serving a similar function. Mr Head's article replicates the error analysis in the original paper but I recommend that your readers have a look at the original article. 'Seasonal Markers for Analemmatic Sundials' was pub-

lished in the NASS Compendium, in Sept 2003 and in the NASS *Sourcebook for Analemmatic Sundials*. Anyone is free to download the article at my personal website www.walkingshadow.info. The picture on the home page shows an analemmatic sundial in Calgary, Alberta with these seasonal markers. Follow the links to Walking Shadows (Sundials) and click on #10 'Seasonal Markers for Analemmatic Sundials' a 205 kb pdf file.

Helmut Sonderegger's program *Alemma* available at <http://web.utanet.at/sondereh/sun.htm> is the best program I know of to calculate these sundials and seasonal markers. But there is a difference of opinion on minimizing error from Head, Sonderegger and Bailey. Head suggest calculating the seasonal marker using the solstices. Unfortunately this is an extreme point. Sonderegger suggests using declination 20.2°. This minimizes error assuming a Gaussian normal distribution for that error. But this error is not normal but

harmonic. My recommendation is to calculate the seasonal marker position for both extreme positions, the solstice and the equinox* to define the range and selecting the average value in between as the seasonal marker point. A disc with a diameter equal to the range centered on the mid position makes a great seasonal marker. If instrumental accuracy is required, use the correction epicycle

outlined in the original paper. This would allow you to set up a theodolite on the marker and use the analemmatic sundial to show you exactly** when and where the sun rises and sets.

* Not exactly the equinox due to zero and infinity problems. Use a declination of 0.01. This is close enough for sundials.

** The usual cautions on refraction, semi-diameter and horizon apply.

*Roger Bailey
Walking Shadow Designs
N48.6 W123.4*

It is worth noting that, for an analemmatic sundial at latitude ϕ the correct places for the seasonal markers, when the declination is δ , is on the major axis of the ellipse a distance d either side of the date line, where d is given by:

$$d = a \cdot \frac{\cos \phi}{\cos \delta} \cdot \sqrt{\cos^2 \phi - \sin^2 \delta}$$

In this expression, a is the semi-major axis of the ellipse.

This expression readily explains many of the observations which have been made:

1. It is clear that a depends on the declination and is at a maximum at the equinoxes (when $\sin^2\delta=0$) and at a minimum at the solstices (when $\sin^2\delta$ most significantly reduces the value of the term under the square root).
2. Fortunately, the declination is confined to the range $\pm 23.5^\circ$ so, very often, $\sin^2\delta$ may be ignored, especially when the latitude is small and $\cos^2\phi$ dominates the term under the square root. The denominator $\cos\delta$ is always close to one.
3. At the equator $\phi=0$ and the entire expression reduces to a , so the markers are at the ends of the major axis and do not change with declination. (The minor axis is zero but that is not a problem.)
4. At the equinoxes $\delta=0$ and the expression reduces to $a \cdot \cos\phi$. This is the proper position for the markers at the equinoxes.
5. At higher latitudes, when $\cos\phi$ loses its dominance over $\sin^2\delta$, the markers move much closer to the date line, and changes in declination give rise to much greater variability in the position of the markers.
6. In the Arctic or Antarctic the term under the square root can go negative and the whole concept fails. This is simply because there are periods when there is no daily sunrise and sunset.

There has been some discussion about choosing the best value of a , given that it varies as the declination changes. Over a year, the solar declination changes slowly at the solstices and rapidly at the equinoxes. Accordingly, the best value of a should be biased towards its value at the solstices.

The expression needs to be modified to reflect how the declination (and hence d) varies with time:

$$d(t) = a \cdot \frac{\cos\phi}{\cos\delta(t)} \cdot \sqrt{\cos^2\phi - \sin^2\delta(t)}$$

One may imagine t representing the fraction of a year (from one vernal equinox to the next) and consider a plot of $d(t)$ as t runs from 0 to 1. The average value of d on this plot is the correct value to choose and this average is obtained by integrating the expression with respect to t as this runs from 0 to 1.

*Frank King
Cambridge*

Ken Head replies:

In reply to Frans Maes, my comment that Lambert circles are of only theoretical interest was made in the context of a basic dial that can be easily marked out on a lawn by a novice such as myself. I did not intend any disrespect for mathematical precision, because I also consider that it is the 'real stuff'. (I have now proved the validity of these circles

to my own satisfaction.). If I am ever in The Netherlands again I shall try to visit Ootmarsum to see the wonderful dial to which Mr Maes refers.

Regarding Roger Bailey's recommendation to use the mean of the extremes as the marker point, I included this suggestion in the paragraph relating to a tabletop dial. This does seem to provide the most satisfactory compromise.

I was pleased when I saw Frank King's confirmation of the relationship I had derived for the distance d of the seasonal markers at any given date, and his subsequent comments neatly summarise several other points. I have used his equation to provide an alternative approach to the problem. Instead of adjusting the position of the sunrise marker, why not make the correction on the date scale itself by plotting offsets from the centre-line equal to the difference between d for a given date and d at the solstices? Alignment with the 'solstice' marker point will then give the true direction of sunrise on that day. It won't provide the time of sunrise, but this can be obtained from a parallel line through the date point on the centre-line. The 'offset' curve for my garden dial is shown below, the maximum offset being about 160mm. Its reflection will be the corresponding offset for sunset. Each curve will lie on the side of the centre-line opposite to the corresponding marker point on the major axis. Has this suggestion been made before?

Many thanks to all for taking the trouble to submit your interesting comments.

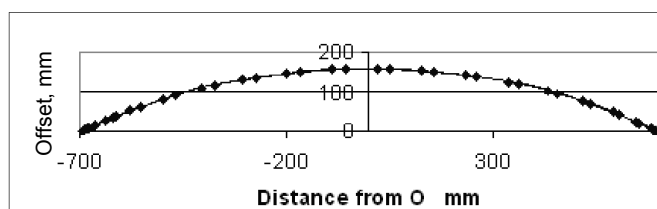

Sunrise marker offsets on date scale (for 51.33° N)

Noon Cannons

I am the South African maker of the noon cannon featured in your September *Bulletin*. As requested, herewith a description of its making.

Brass is the material of choice because it is freely available. Marine bronze should be used for the cannon but that is not available here. Whilst the project may seem huge at first, each piece is simple on its own and the modern waterjet cutting and laser cutting methods make the task much simpler, plus turning the cannon on a CNC lathe is basic stuff and a dividing head on a milling machine will position the cannon hinge pin holes and touch hole accurately.

The choice of dial plate diameter is arbitrary, in this case 300mm. Accurate drawing is essential and I use Corel Draw which for technical drawings is excellent and

accurate, plus the drawings can be saved in the .dxf (AutoCad) format which the laser people will require. If all of the components for laser or waterjet cutting are drawn on one page, only one dimension need be added to the drawing. The laser guys will drag the drawing to that dimension in AutoCad and the rest will scale proportionately when cut.

The cannon bore was 5mm. That was to suit the Tom Thumb squibs in the picture. I think you call them 'fire crackers' in England. They are illegal here but you can still get them! If the cannon was to use black powder the bore would have to be larger, maybe even 10mm. A squib was rammed, fuse first, down the barrel. Then two fuses from other squibs were inserted into the touch hole. 100% reliable firing was achieved. Here it must be remembered that we have 84% cloud free days and not much rain. The cannon must be dry inside before any firing attempt. The sundial was designed to have the cannon fire at local solar noon and so was longitudinally corrected. Those calculations need not be given here but the sundial took up half of the dial plate.



The observed backblast from the touch hole when using squibs was very little so the focal length of the lens could be fairly short and was quite simply a child's magnifying glass from a toy shop. Beware of hardened glass lenses, they chip badly when ground to fit the lens carrier. In the second cannon I made, I used a far longer focal length because I was not certain of the backblast when using black powder and could not test that. The positioning of the lens on its brackets above the touch hole is easy and no calculations are required. Use the sun, but the height of the focused point of light must be exactly in line with the touch hole. Thus the magnifying glass brackets and the cannon position's holding-down points can be drawn into the dial plate before etching. Obviously the cannon and magnifying glass assembly must be made up and accurately measured before completing the dial plate drawing. Here I made the cannon first and then completed the magnifier bracket drawing. This last point is very important because final drilling of the plate, cannon and magnifier brackets then becomes simple but could be very difficult to do accurately by eye if the above steps are not followed.

I send out my laser or waterjet cutting and etching. Final assembly and polishing is about 4 hours work. Drawing is about 2 hours and travelling about 4 hours. The recent

vast increases in the price of brass still make the Noon Cannon Sundial an expensive toy.

The cannon is probably equally as illegal in the UK as it is here, but I care not, I will continue to make them, my name is not Bin Laden!

A stern word of warning though. No projectile must ever be inserted into the barrel. I tested this with a 5mm steel ball bearing and, using the squib, it went halfway through a house brick. Normal firearm and explosive safety measures and procedures must be applied at all times and the 'weapon' must never be left unattended, especially around children, of all ages.

Malcolm Barnfield
South Africa
www.sundials.co.za

Half a Motto

An item from *The Recorder*, reprinted in the last *Bulletin*, asked for help with a motto which appeared to read "...eagum". Having failed to think of an explanation for this partial inscription on the half dial at St. Andrew's, Kenn, I wrote to the Priest in Charge, the Rev'd John Williams to ask if he could help. He kindly sent me some information supplied by one of his parishioners, Roger Hurles, who had found an entry for 1783 in the churchwardens' accounts which ran:

Pd Mr Peagam for sundial by contract £1-11-6d
Pd him for labour to put it in place 3/6d

Mr Williams added that the name Peagam is also found as Peagum so I think the mystery is solved.

John Lester
Walsall



A vertical declining dial in the form of a fridge magnet. You might need to leave the door open to get the right alignment! Photo: Peter Ransom.

MAKING PORTABLE DIALS IN SILVER

JACKIE JONES

I first started making portable dials in silver about seven years ago after seeing collections at the National Maritime Museum, Greenwich, and the Science Museum, London. I realised that they were made using the same jewellery techniques that I had been trained in at Art College and have been using to make jewellery since. I decided to revive the pocket dial in modern designs; my aim was to move away from the traditional styles of engraved lines and numbers. They are intended to be seen as a piece of art as well as being functional.

I have used different methods to show the hour lines and numbers so they form part of the design; they can be engraved, punched or formed of fine silver wire. The blackening of recesses is achieved chemically by painting with a solution of potassium sulphide. Numbers can be punched, but not necessarily for each hour. Some dials have no numbers, but use gold or silver granules or stars instead.



Fig. 1. Back of vertical south dial necklace showing hinged gnomon.

Each dial is individually made for the required latitude and can either be placed on a table in a window or carried around with the owner. Necklaces, vertical south dials, have the chain attached at the top so they hang vertically. The gnomon is hinged and lies flat on the back of the dial plate (Fig. 1). To use, it is turned over to the front where it will lie at the correct angle in a shaped recess. The centre part of the hinge is longer than the width of the gnomon to prevent movement. Dials which can be carried in a pocket or bag also have folding gnomons (Fig. 2). They are hinged so they lie flat on the dial plate when not in use; the gnomon has small stop on it to keep it at right-angles to the plate when standing up.

To aid accuracy of the gnomon angle, I have produced a collection of small right-angled triangles of brass or copper (Fig. 3) which can be laid on the silver sheet and scribed around with a steel point before cutting. They are also used as an aid in positioning the gnomon hinge to ensure the style base is on the 6-6 line. The gnomon is normally made from sheet 1mm thick which ensures it is strong enough to have a cut-out design and not deform. This 1mm thickness obviously has to be allowed for in marking the hour lines.

Sterling silver is a relatively easy material to work with; I buy it in a variety of forms such as sheet of different thicknesses, wire or tube. Many of the techniques involved in the dial's manufacture are similar to those that have been used in previous centuries; metal is cut with a small handsaw (Fig. 4), the blade being only 0.25mm wide. It is filed with hand files of assorted shapes and then smoothed with emery paper. The pieces are soldered together with a

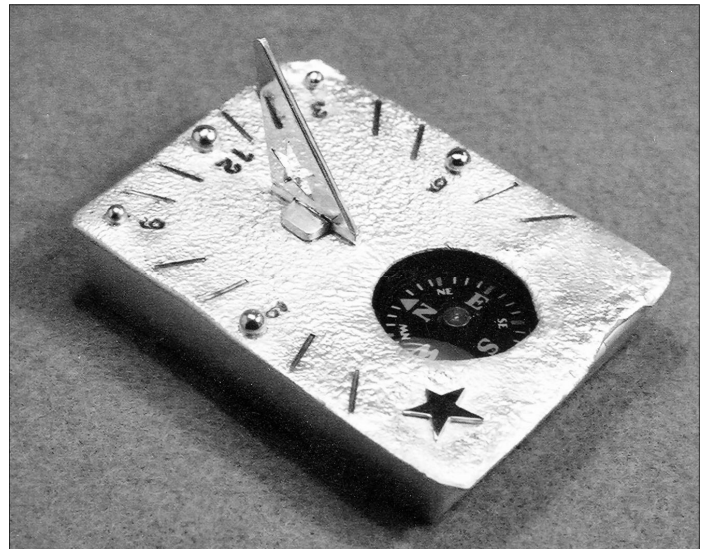

Fig. 2. Box horizontal dial with hinged gnomon.

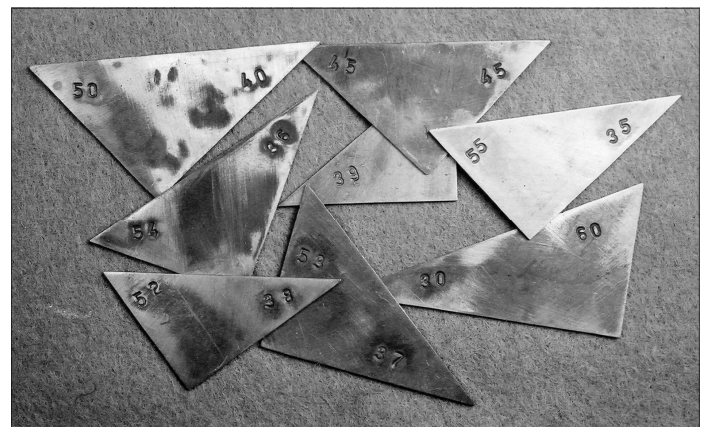

Fig. 3. Templates for cutting gnomons.



Fig. 4. The author in her workshop sawing silver.

When the piece is completed, it is sent to the London Assay Office to be hallmarked. The metal is tested; traditionally by scraping off a small sample to melt, but now it is done using an x-ray fluorescence machine which is non-intrusive. If it is up to quality, it is stamped with the maker's initials, the assay office, metal type and year marks.

The surface of the dial plate provides interesting challenges; polished silver will not show a shadow well, just a lot of reflections.

There are many methods of achieving a matt surface, some illustrated here. In Figure 6, a polar dial, the main plate has been put through steel rollers with two grades of sandpaper on the silver which impressed their texture into the metal. The small 'hills' at the lower corners were made by putting the silver through the rolling mills with a piece of the hook side of Velcro. The surface in Figure 7 was also achieved using rolling mills, this time with a layer of steel wire wool pressed onto the silver sheet. The surface finish on the box lid in figure 2 is created by repeated high temperature heating and cleaning in acid of the silver sheet. The gold star and beads were soldered on afterwards.

One of the problems with sterling silver is the appearance of a dark surface layer called fire-stain, caused by a reaction between oxygen from the air and the copper content of the metal when it is heated. It is removable by filing or sanding with emery paper but this has to be allowed for on accurate sections of a dial that are to be polished, such as the style on the gnomon. Depending on how many times a piece has been heated, I would allow up to 0.1mm extra metal to remove in the final polishing stage.



Fig. 5. Hinge on horizontal dial prepared for soldering.

gas blow-torch using solder of silver which has been alloyed to reduce the melting temperature while still being of hall-marking standard. Figure 5 shows a hinge for a gnomon set up ready to be soldered, with a steel pin through the tubes to keep them in line while heating. Small paillions of solder are placed on both sides of the tube to produce an even, secure joint. I also use other purpose-made supports to ensure other pieces such as fixed gnomons stay in place during soldering.

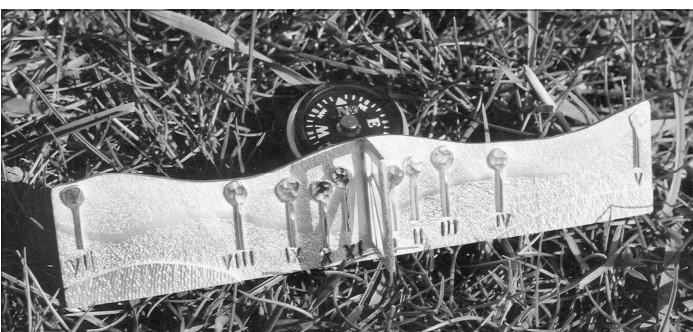

Fig. 6. Polar dial showing surface textures.



Fig. 7. Silver and gold necklace showing wire wool texture.

The dial is then assembled and polished. First, fine grades of emery paper are used on surfaces to be shiny, then tripoli, a finer abrasive polish which is used with a small mop on an electric motor. A high shine is then achieved with rouge, which is an even finer compound. Hinges are assembled with a tight-fitting silver pin. This is riveted by spreading the wire over the tube ends with a small punch and hammer. Matt surfaces are finished with either a brass brush and soapy water or a glass brush – a bunch of fine glass fibres. This completes the dial.

In future designs, I plan to include transparent enamel panels, especially on the gnomon. I often use a cut-out pattern and this could be filled with enamel using a technique known as ‘plique-a-jour’ which would create a moving pattern of coloured light across the dial plate.

I welcome visitors to my small studio but by appointment only as I also teach jewellery from there.

*Author's address:
51 Upper Lewes Road
Brighton, BN2 3FH
Jackie@waitrose.com*

Postcard Potpourri 6 – People’s Park, Halifax

Peter Ransom

This postcard features the sundial in this classic Victorian park, designed by Joseph Paxton, in Halifax (postcode HX2 0AY). The park, in King Cross Street, was created in 1857 and donated to the people of Halifax by Sir Francis Crossley, to be maintained by the then Halifax Corporation for all time. The recent restoration work (mentioned on a website) has allegedly rescued the park from its decline, but I am unaware of the current state of the sundial.

Alderman Matthew Smith, a one-time Mayor of Halifax, presented

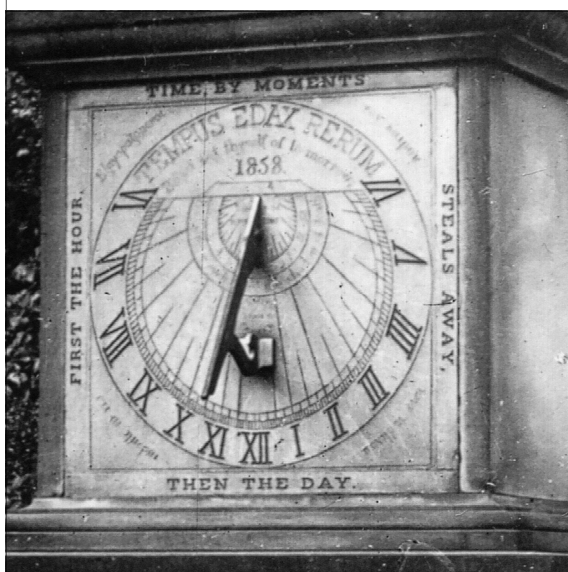

the dial to the People’s Park in 1873. Enlarging the dial part of the postcard shows this to be a vertical south dial with the motto around the square border being ‘Time by moments / steals away. / First the hour, / then the day.’ There appears to be a text in Greek around the circumference of the dial and the Latin text above the gnomon reads ‘TEMPUS EDAX RERUM’ (*Time consumeth all things*) ‘Boast not thyself of tomorrow 1858.’ According to Mrs. Gatty (*The Book of Sundials*, 1900) the identical mottoes appear on the dial by Mr. J. Smith of South Stockton that is in Albert Park, Middlesbrough. The dial is calibrated to 5-minute intervals. Unfortunately, despite scanning at the highest resolution, the inscription behind the gnomon cannot be read. There is no indication of the date of the photograph on the postcard, though by the style of the card and prams in the picture I think it is probably early 1900’s.

pransom@btinternet.com

JOHN ROWELL

PLUMBER AND STAINED GLASS DIAL MAKER

JOHN DAVIS

Stained glass sundials were very popular in the 17th century but largely died out in the early 18th century, before making a comeback in the Victorian and Edwardian periods.¹⁻³ Of the known 18th century dials, most were made by the London-trained Price family but two came from a John Rowell, provincial plumber and water engineer who appears to have become a self-taught glass painter.

Most of what we know about John Rowell comes from an excellent short biography of him by local historian Sidney Gold.⁴ Rowell was born in 1689 and married Mary Berry, from Hackney, in 1712, where Rowell's father may have originated. They settled in (High) Wycombe where Rowell's relations had lived for many years. The couple had several children but only Francis, b.1714, survived into adulthood. Rowell bought property in Curney Lane and established himself as a tradesman, particularly as a plumber and glazier. He was evidently an intelligent and enterprising individual as he was soon in demand as a water engineer at many large houses in the area. He was also a painter and there are some accounts of his work on canvas in the 1720s. It was not until 1733, however, when he was

well into his forties, that he promoted his services as a glass painter with advertisements in the *London Journal* (27 Jan 1733, new style) and the *Craftsman* (3 Feb 1733) giving a list of his recent achievements in this field. These were chiefly religious subjects in churches and large houses. He also produced a tradecard (Fig. 1) along similar lines advertising

*The Antient Art
of Staining of Glass*

with all the Colours, revived and Performed by John Rowell, at Wycomb,...

The advertisements also state that

He also makes Sun-Dials and Coats of Arms in the Stain'd Glass, and repairs any ancient works in that Art.

They make it clear that his son Francis is expected to carry on the business and that experiments and demonstrations are to be seen in his house in Wycombe. This, together with observations of his existing work, indicate that he was self-taught and developed his methods himself. This was not altogether a good thing as many of his colours were merely painted on.

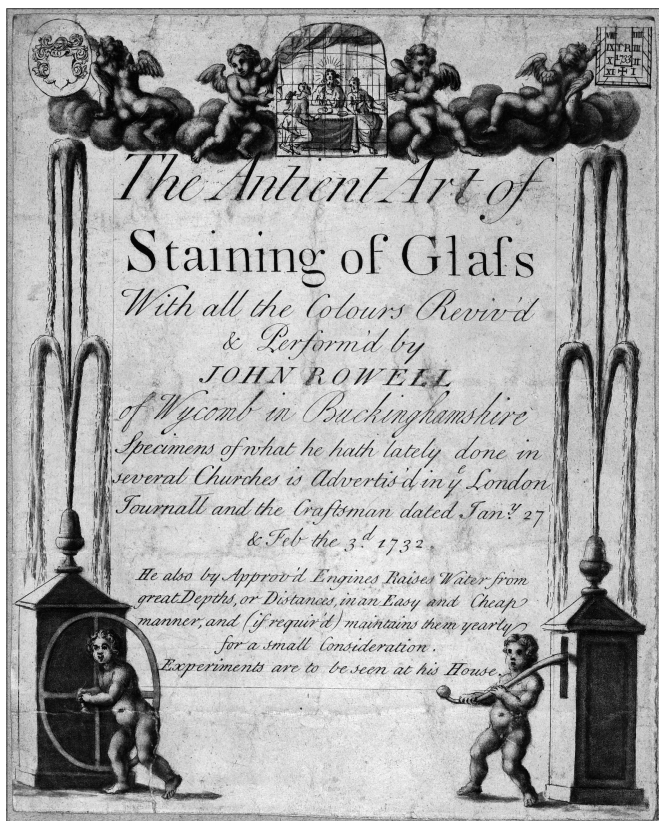

Fig. 1. John Rowell's tradecard. Courtesy of The Bodleian Library, Oxford. (Douce adds. 138(110) title page).



Fig. 2. Portrait of John Rowell by John Weller. Courtesy of The Trustees of the British Museum, 1852-2-14-371.

Francis Rowell died young in 1744 after a long illness and although he is known to have done some plumbing jobs he is not believed to have painted glass. John Rowell took an apprentice, William Truss in 1743 but again he is only known for his plumbing work. We do owe to Truss the fact that we have a portrait of John Rowell whom he clearly regarded highly. The actual pencil drawing he commissioned is now lost but the preliminary sketch, in black chalk, does exist (Fig. 2). On it is written, possibly in a later hand, “*John Rowell plumber and glass painter of Reading, Berks., - extremely like. J Weller Delin*”. Weller was an obscure contemporary of Rowell who lived in Reading. Rowell appears as a rather distinguished gentleman: despite being a tradesman he was relatively wealthy due to inheritances.

The Arbury Hall Dial

Rowell’s first stained glass sundial is now at Arbury Hall near Nuneaton, Warks. (Fig. 3 in colour on page 183). Its original location is unknown as it was moved to Arbury Hall in 1785 when Sir Roger Newdigate, the 5th Bart, bought it from a dealer, James Broden, among a job-lot of stained glass with which he wanted to adorn his newly built cloisters.^{5,6} Presumably, the original house had been demolished. The dial is signed only “*IR 1733*” but there can be little doubt that this is Rowell’s work because the form of the dial follows closely that shown in the top-right corner of his tradecard (Fig. 4). Strangely, the drawing shows a dial which is mirror-imaged for a vertical stained glass dial

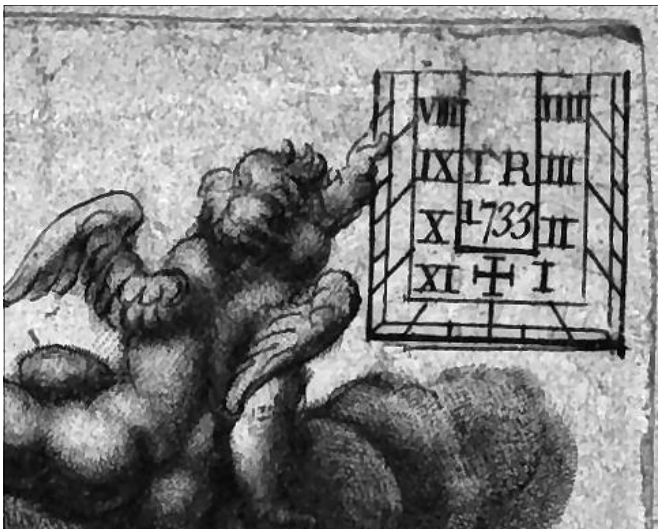

Fig. 4. Close-up of the top-right corner of Rowell’s tradecard (Fig. 1) showing a dial similar to the Arbury Hall one.

though the actual dial is correct. It is 235mm wide by 300mm high and although now cracked it is painted sufficiently accurately for the traditional fly to be identified as a flesh-fly (*Sarcophaga carnaria*) though the butterfly seems to show characteristics of both a large and a small tortoise-shell. The dial is rather badly cracked and clumsily repaired

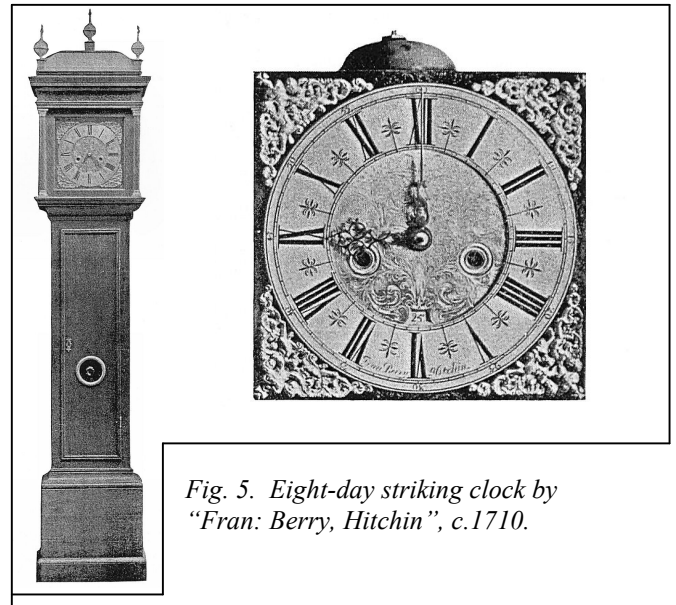

Fig. 5. Eight-day striking clock by “*Fran: Berry, Hitchin*”, c.1710.

but there do not appear to be any holes in the glass for mounting the gnomon.

Where did Rowell obtain the knowledge to allow him to delineate a sundial? One strong possibility (though pure speculation) is through his father-in-law, Francis Berry. Berry was a clockmaker, working from Hitchin:⁷ at least one longcase clock by him is known (Fig. 5). Many clockmakers also produced dials. Berry’s will, written in 1723, bequeaths “*...and to her husband John Rowell I give my large horizontall dyall showing the azimuths and point of the Compass and every second minute*”. Thus we can assume that Rowell knew of this dial 10 years before he made the Arbury Hall one though he had to wait until Berry’s death in 1741 to inherit it.



Fig. 6. The south front of Purley Hall near Pangbourne. The stained glass dial in the the central upper panel of the ground floor windows on the right.

The Purley Hall Dial

Rowell’s other known dial^{1,9} was made in 1734 for Purley Hall near Pangbourne (Fig. 6), quite close to his home. I first became involved with it when the new owners of the Hall sought more information about it from the Stained Glass Dial website.⁵ Through a message from John Carmichael⁸, I was able to visit and to assess this fine dial

(Fig. 7). This time the dial is signed in full and it also has a complicated monogram for FS. It was painted for Francis Hawes, then the owner of the Hall. Rowell painted two other windows at the same time, these being armorials for Hawes and his lately deceased brother-in-law John Leng, Bishop of Norwich (Fig. 8).

The dial is a large one (approx 25½" high by 18½" wide) on nine separate panes of glass with the lower-right one having a repaired crack. It is now protected by a single large pane of clear glass fixed in the stone mullion outside it with a gap of around half an inch. As in the Arbury Hall dial, there are no holes in the glass which could have served to mount a gnomon. It has the motto *Umbræ Summus* (we are a shadow) and, unusually, a second time scale delineated for Constantinople. The reason for this is not clear but may possibly be linked to the (in)famous South Seas Company, of which Francis Hawes was a one-time director. The time offset to local solar time is shown as 2¼ hours although for the true longitudes of Pangbourne (1° 4' W) and Constantinople (31° 0' E in Atkinson's 1735 *Epitome of the Art of Navigation*, 29° 0' for Istanbul in a modern atlas) it should be more like 2 hours.

Looking at the main dial in order to calculate its design parameters for a gnomon reconstruction, it was quickly apparent that although the origin of the dial is clearly vertically above the noon cross patté and just off the top of the glass, not all of the hourlines point to it. Indeed, the hourlines for just after noon seem to have totally the wrong slope. The effect can be localised to the lines on the central glass panel and it was at first thought that this pane could be a replacement, especially as, when viewed from the outside, it has a mysterious white rectangle (Fig. 9). Close examination of a b&w photograph of the dial (Fig. 10) taken by Sidney Gold⁴ in c.1966 shows that this panel has since been



Fig. 9. The Purley Hall dial viewed from the outside. Note the white rectangle in the central pane. A reflection of the author and the camera can just be seen.

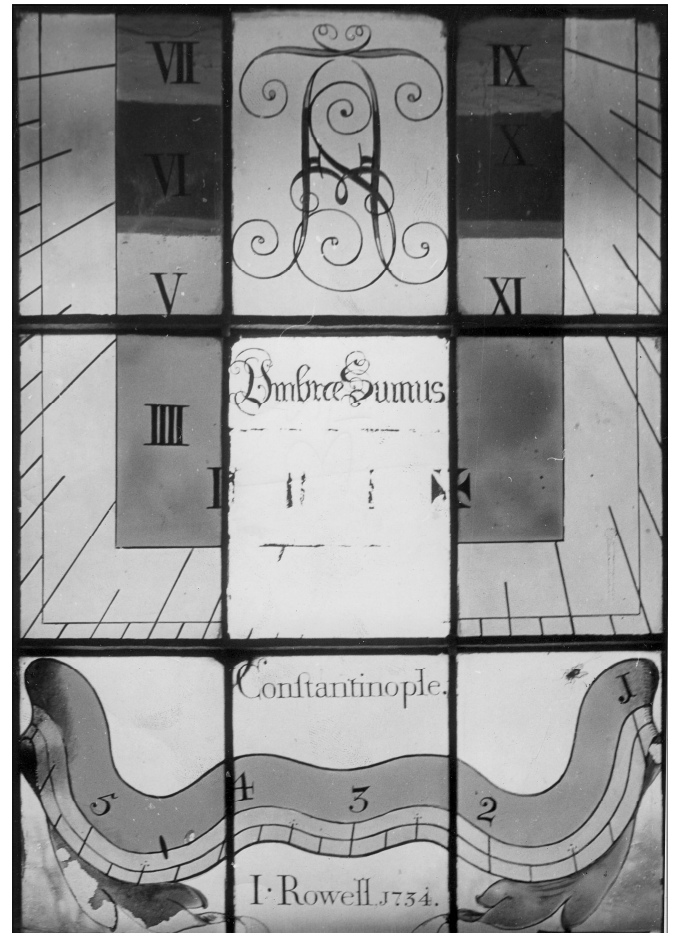

Fig. 10. Black-&-white photo of the Purley Hall dial, c.1966. Compare with Fig 7. Photo © Mr Sidney Gold.

restored as the red background colour had failed completely and only a few remnants of the hourlines were then remaining. The restoration must have been performed in the period between 1966 and the mid 1980s when Christopher Daniel^{1,6} photographed it looking essentially the same as it does today. Whoever did this restoration managed to

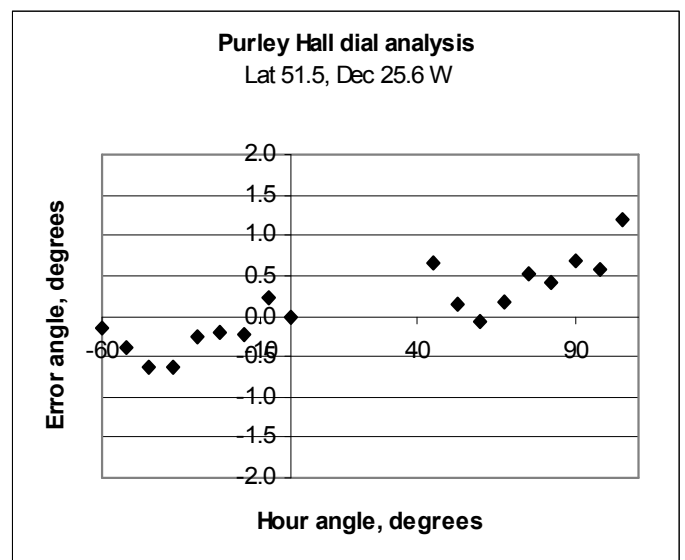

Fig. 11. Error analysis of the hourlines on the Purley Hall dial, for a design latitude of 51.5° N and a best-fit declination of 25.6° W. The lines from the central panel have been omitted.

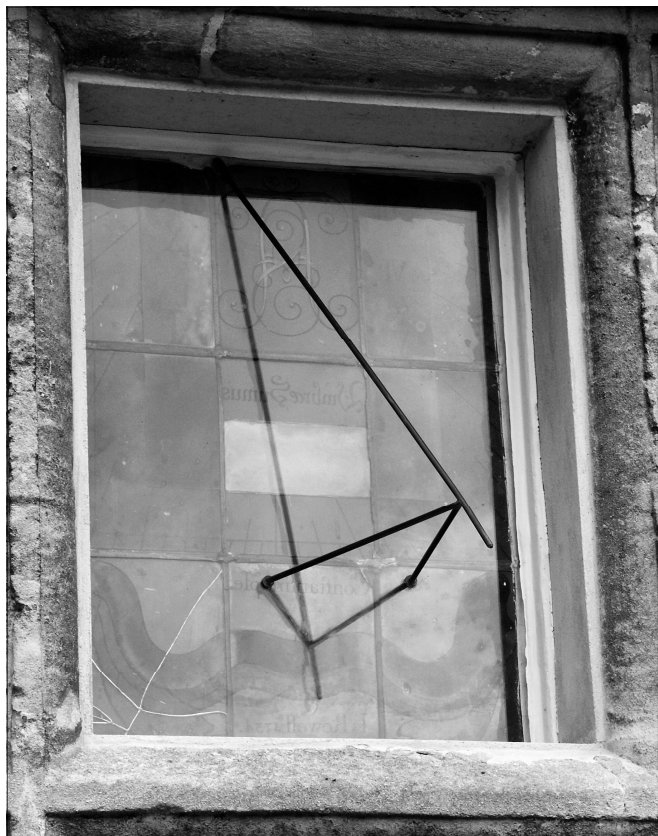

Fig. 12. The replacement gnomon attached to the outer, protective glass sheet.

achieve a reasonable match to the red background colour by backing it up with a white undercoat on the outside but clearly had no idea of how a sundial is delineated. It also seems that they broke the bottom-right panel in the process as it is undamaged in Gold's photograph.

Analysis of the original hourlines (Fig. 11) shows that a good match to the dial's location can be achieved by assuming a window declination of 25.6° W, giving a standard deviation of the individual errors of 0.49° . This declination value was used for the gnomon reconstruction. It was also clear, from a bulge in the putty surrounding the dial, that the original gnomon was actually fitted directly into the frame. It was probably a simple self-supporting rod. The replacement gnomon (Fig. 12) was design to be fitted directly onto the outer protective glass pane and is of patinated brass. It was attached by means of UV-curable adhesive. The fixing was purposely not made too secure so that, should a branch of the wisteria which grows up the south front, or the gardener's loppers, hit the gnomon, it will detach rather than shatter the outer glass and endanger the dial.

Epilogue

Rowell continued to produce stained glass windows up to at least 1751 and is known to have been experimenting with

painting techniques in his last years: he is said to have at last developed a durable red. No further stained glass dials are known and he died in 1756. One of the witnesses to his will was a Thos Blagrove so it is interesting to speculate whether this might be a descendent of the famous mathematician John Blagrove whose large memorial is in the nearby Reading church. After his death, his (second) wife sold off the demonstration glass panels which were at his home. One of these is *St Luke Painting Christ as the Man of Sorrow* which, together with other work by Rowell, is now at The Vyne (NT) near Basingstoke (Fig. 13). It has been suggested¹⁰ that the figure of St Luke is in fact a self-portrait. Certainly, comparison with Fig. 2 does show a number of common features, particularly the high forehead. The choice of the subject (St Luke is the patron saint of painters) also seems to be significant.

John Rowell appears very much a one-off amongst dial-makers. We can only hope that more of his work may one day be discovered.

ACKNOWLEDGEMENTS

It is a pleasure to acknowledge the permission of Tom and Nicky Anderson to photograph the Purley Hall dial. I am very grateful to Sidney Gold for copies of his original photograph of the dial and for much useful information. John Carmichael introduced me to this topic and Christopher Daniel has also kindly provided information and the photographs of the Arbury Hall dial

REFERENCES

1. C. Daniel: 'Umbræ Sumus', The Sundial Page, *Clocks*, 26(10), (Nov 2003).
2. Articles in *Bulletin* 19(ii), (June 2007).
3. G. Lane: 'Glass Sundial Makers of 17th Century London', *BSS Bulletin*, 18(i), pp 40-47 (Mar. 2006).
4. S.M. Gold: *A short account of the life and work of John Rowell*, Privately published; printed by Ranelagh Press, Reading (1965).
5. Stained Glass website: www.advanceassociates.com/Sundials/Stained_Glass/
6. C Daniel: private communication.
7. B. Loomes: *The Early Clockmakers of Great Britain*. NAG Press, London (1981).
8. J. Carmichael, private communication.
9. M. Cowham (Ed.): *Sundials of the British Isles*, Cowham, Cambridge (2005).
10. C. Rowell: 'Stained glass by John Rowell and William Price the Younger at The Vyne', *The Burlington Magazine*, pp.443-451, CXLV (June 2003).

Author's address:
john.davis@btinternet.com

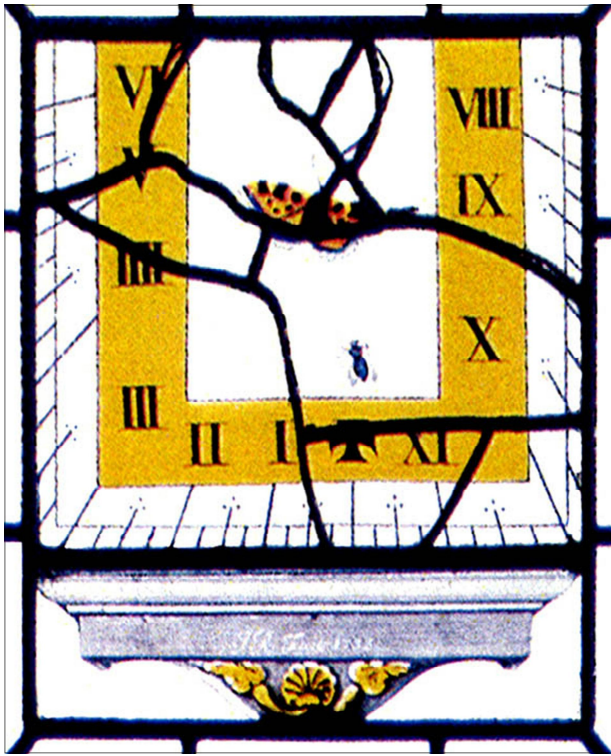

C. Daniel

Fig. 3. The 1733 John Rowell dial, now at Arbury Hall.



Fig. 7. The 1734 John Rowell dial, still in its original location at Purley Hall.



Fig. 8. Stained glass armorials by John Rowell at Purley Hall. Above: Hawes impaling Barnes (west front). Below: Leng impaling Hawes (south front).



Nadia Mackenzie

Fig. 13. "St Luke painting Christ as a Man of Sorrows" by J. Rowell, c. 1750. Now at The Vyne (NT), it is thought to be a self-portrait. © National Trust Picture Library.



Fig. 2 (left). Overall view of the Cala Figuera sundial.

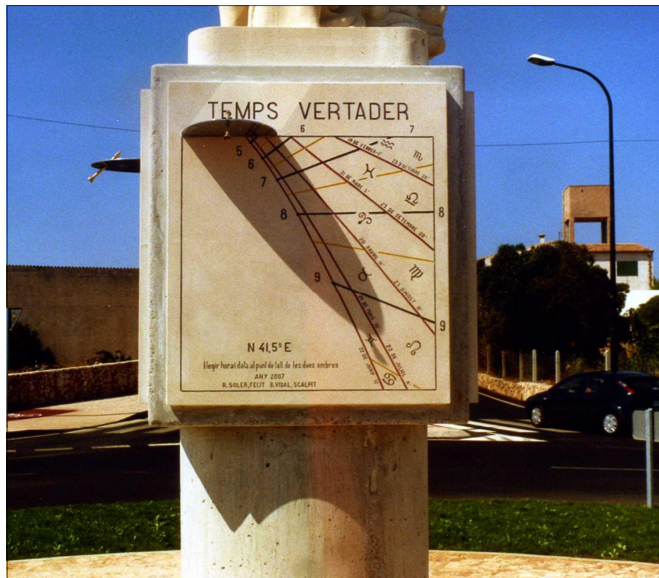
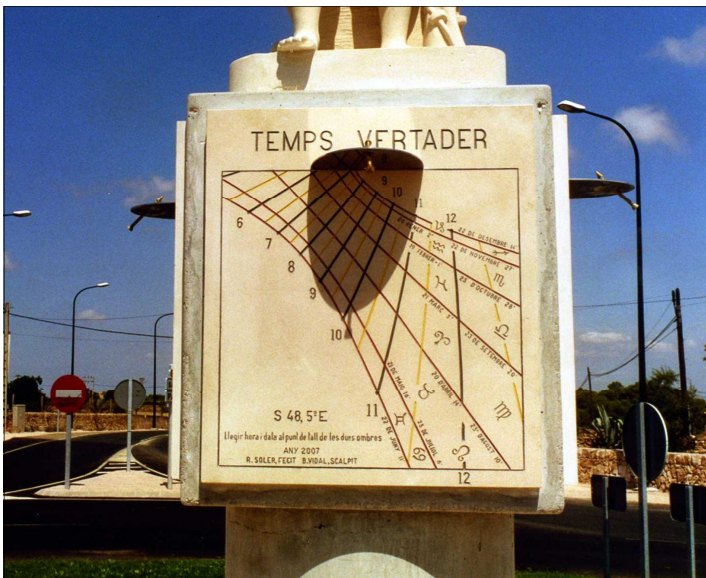
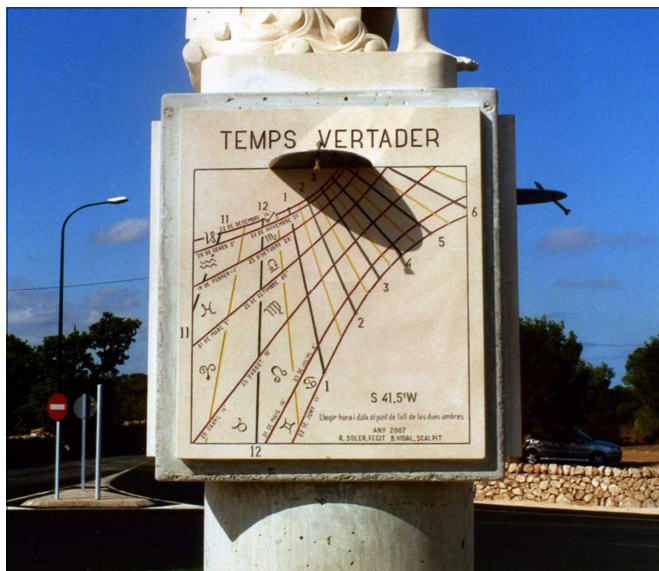

Fig. 3. (right). The view of the sundial from the north.

Fig. 4 (right). The South-West face.

Fig. 5. (below right). The North-East face.

Fig. 6 (below). The South-East face.



A MULTIPLE DIAL AS A MONUMENT TO THE FISHERMEN OF CALA FIGUERA, SANTANYI (MAJORCA)

RAFAEL SOLER GAYÁ

In the centre of a roundabout on the access road leading to Cala Figuera, in the municipality of Santanyi, a monument has been erected to the fishermen of the local fishing port (Fig. 1). Sponsored by the City Hall, it consists of a statue



Fig. 1. The roundabout on the outskirts of Cala Figuera with the sundial monument.

of a sailor who, with a fishing net over one arm, steers a ship with the tiller of the rudder in the other hand (Fig. 2). On the faces of the prismatic part of the statue's pedestal - oriented to face the feeder roads to the roundabout - there are three vertical declining dials. The pedestal is of concrete and the sculpture and the dial plates are of the typical fine sandstone named after the municipality (Figs. 4-6 on p.184).

Two of the dials are south facing, declining to the East and to the West, and the third is north facing declining to the East. The three dials (each 90cm wide by 105cm high) are of the bifilar type, in each case having the two gnomons formed by a horizontal semi-ellipse and a straight line, in the shape of an arrow, which passes through the ellipse focus and is inclined at 45° to the perpendicular to the vertical plane of the dial face. The dials are delineated to show hours and half-hours and also have declination lines for the entrance of the sun into each of the zodiac signs which are also labelled with the calendar dates.

As is traditional for sundials, the dials show Local Apparent Time which is read at the point where the shadows of the arrow and the semi-ellipse intersect. To convert from the time indicated by the dial to official Civil Time, that is to say the given by ordinary clocks and watches, the time is corrected by adding or subtracting the value engraved (in

minutes) after the name of the month on each declination line. Because of the local longitude, for most of the year the dials are fast.

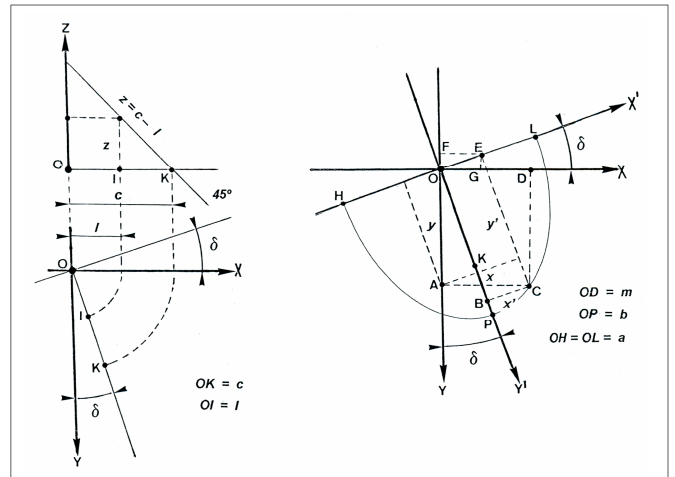

Fig. 7. Coordinate systems for the parametric equations of the gnomons.

The design methods for the hour- and declination lines of a bifilar dial have been given previously,¹⁻⁴ most notably in English in the NASS Compendium.⁵ Thus only the details for this particular case are given here, using the notation and formulae given in Ref. 5. Using the centre O of the ellipse as the origin of coordinates in each case (see Fig. 7) and with a declination δ of each face we obtain the expressions below. [Note that δ does not have its usual meaning of the sun's declination here - Ed.]

The parametric equations of the linear gnomon are

$$x(l) = l \sin \delta, \quad y(l) = l \cos \delta, \quad z(l) = c - l \quad \dots (1)$$

and the equations of the elliptical gnomon are

$$y = OA = AF - OF = EC \cos \delta - OE \sin \delta$$

$$x = OD = GD + OG = EC \sin \delta + OE \sin \delta$$

For the ellipse canonical equation, referred to the axes OX' and OY' (Fig. 7) and assuming OE = m as a parameter, we have for the semi-axes a and b:

$$\left. \begin{aligned} x(m) &= (a^2 - m^2)^{1/2} (b/a) \sin \delta + m \cos \delta \\ y(m) &= (a^2 - m^2)^{1/2} (b/a) \cos \delta - m \sin \delta \\ z(m) &= 0 \end{aligned} \right\} \dots (2)$$

$$OE^2/a^2 + EC^2/b^2 = 1 \quad EC = (a^2 - OE^2)^{1/2} b/a$$

Using the set of equations (10) in Ref. 5, l can be expressed in terms of m and we obtain:

$$[z_0 \sin \delta + x_0][z_0(a^2 - m^2)^{1/2}(b/a) \cos \delta - m z_0 \sin \delta + c y_0] = z_0 \cos \delta + y_0[z_0(a^2 - m^2)^{1/2}(b/a) \sin \delta + m z_0 \cos \delta + c x_0]$$

This expression can be solved numerically by computer for each of the faces with $\delta = 48.5^\circ$; -41.5° and 138.5° in turn, and with the constant values $a = 13.22\text{cm}$, $b = 20\text{cm}$ and $c = 15\text{cm}$ and with the values x_0 , y_0 , z_0 for the latitude $\varphi = 39^\circ 19.5' \text{ N}$, giving the hour angle for each quarter of an hour (although the actual dials only display half-hours because car drivers will not have time to study them carefully!). Standard values of the solar declination for the start of each zodiacal month were used. This allowed the calculation of tables of coordinates to lay out the hour lines and the curved calendar lines. These (x, y, z) coordinates are referred to the OX, OY and OZ axes and were translated to the corresponding ones (x', z') in the planes of the faces (with axes OX' and OZ' and noting that OZ' and OZ are the same) using:

$$z = -[x(m)\sin\delta + \cos\delta y(m)]/[\sin\delta + \cos\delta]$$

$$x = z + x(m), \quad y = z + y(m)$$

and on the dial face:

$$x' = x\cos\delta - y\sin\delta, \quad z' = z$$

Finally, it should be noted that to avoid the appearance of equation roots in m which really correspond to nocturnal hour angles, the condition that the height of the sun *alt* be positive is applied, that is to say that:

$$\sin alt = \sin\varphi \sin\alpha + \cos\varphi \cos\alpha \cos\epsilon > 0$$

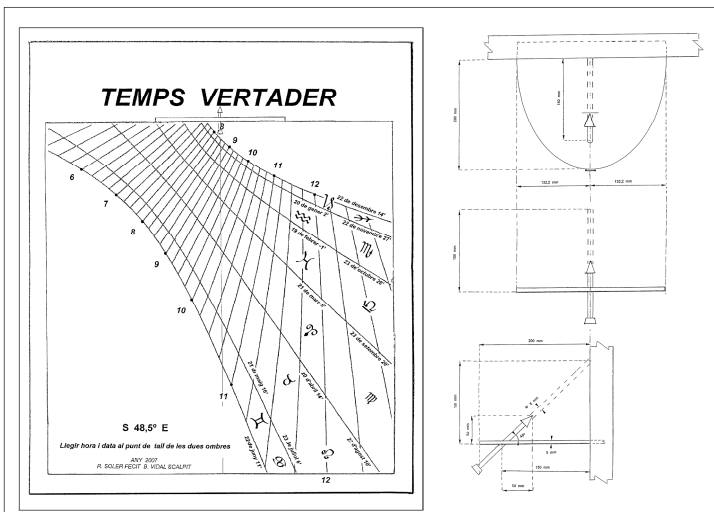

Fig. 8. Drawing of the SE face (left) and (right) the design for the gnomons (all faces).

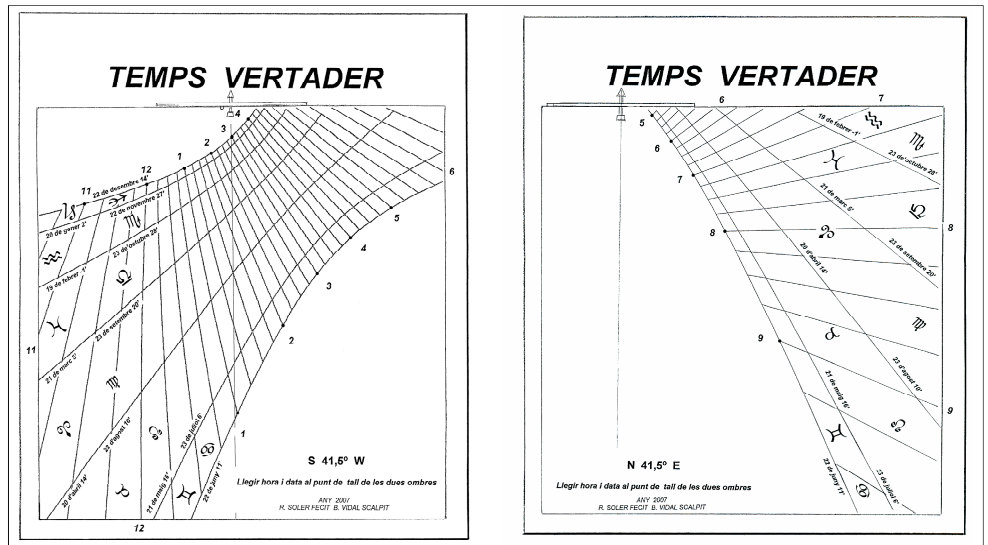

Fig. 9. Drawings of the SW and NE faces.

Also, to avoid solutions which are not of interest, it is convenient to set the condition that $l > c$ when determining m . Thus, only shadow points from the part of the linear gnomon below the semi-ellipse are considered.

Drawings of the dial faces are shown in Figs. 8 & 9.

REFERENCES

1. Rafael Soler Gayá: 'Aplicaciones del método analítico de diseño de relojes de sol bifilares', *ANALEMA* (nº 32 abril-agosto 2001 y correcciones en nº 38.- abril-agosto 2003).
2. AARS corresponds to 'Asociación de Amigos de los Relojes de Sol'.
3. Rafael Soler Gayá: 'Cuadrante bifilar vertical declinante con cadena chorro' (Anexo: 'Aplicaciones del método analítico de diseño de relojes de sol bifilares (fuente)'). *CARPE DIEM*. Edición nº 18.- junio 2006. (www.bernisol.com).
4. Soler Gayá R /Collin D: 'Application de la Methode Analytique aux Traces de Cadran Solaires Bifilaires', *Cadran-Info de la SAF* (nº 6.-octobre 2002).
5. R.S. Gayá: 'An application of the general method for bifilar sundial design', *NASS Compendium*, **13**(4), pp.20-25 (December 2006).

Author's address:
Tous i Maroto n° 6, 1º, 2ª
07001 Palma de Mallorca
SPAIN
solergaya@hotmail.com

A DIAL BY RICHARD MELVILLE IN ANDOVER, HAMPSHIRE

DOUGLAS BATEMAN

A circular horizontal dial by Melville (signed Melvin) has been located in a suburban garden in Andover, Wiltshire (Figs. 1-3). The dial has many similarities with the basic information on the former Salisbury octagonal dial, as fully



Fig 1. The dial in its garden setting, with the slate surface let into the capital of the pedestal. The thickness of the slate is probably of the order of 20mm. The diameter is 332mm (13 inches).

described by Nicholls.¹ The fact that this dial is signed Melvin puts it in the majority form of signature whereas a small number have been signed with the alternative name Melville.^{2,3} Otherwise the dial is something of a rarity.

The dial gives the intended latitude as $51^{\circ} 6' N$ and the longitude may be inferred from the statement that “dial is $7\frac{1}{2}$ slower” than Greenwich. The latter equates to $1^{\circ} 56' W$, which suggests a location a few miles west of Salisbury. Indeed, at this latitude and longitude the maps show a large property and garden called Grovely Lodge. A visit revealed that the use of the property has changed, now being given over to farming with one dwelling. Further enquiries led me to the estate office of Wilton House, the stately home at the heart of the 14,000 acre estate of the Earl of Pembroke. The office in turn passed my enquiry to a local historian who has very extensive knowledge of the former lodge and estates, and he assured me that there was no record of a sundial being on this site, nor in the general area.⁴ It therefore remains a mystery as to how the dial reached its current location, purchased least 40 years ago for a suburban garden in Andover, and then by gift to the present owner across the road, some 20 years later. It may be coincidental that the dial is about 20 miles from its intended geographic area.

Despite the declared latitude, the brass or bronze gnomon has an angle of 53.5° and measurement of the dial hour lines give a much closer fit to a calculation of this latitude rather than $51^{\circ} 6'$ (see Fig. 4). This rather ‘inexact’ ap-

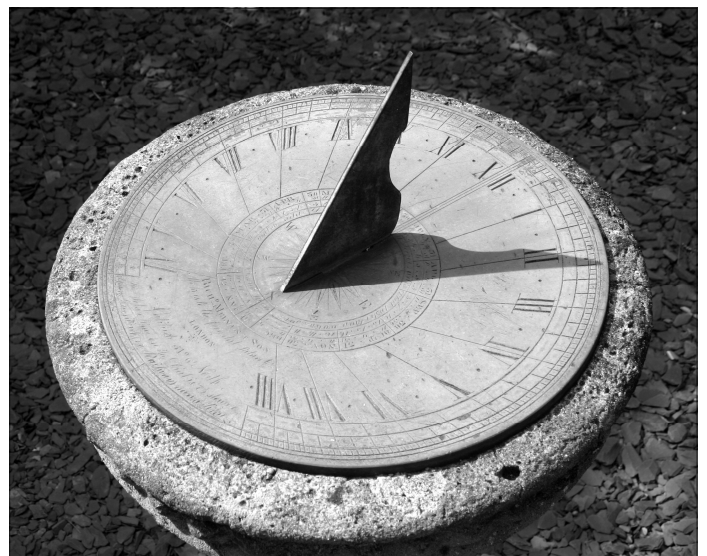
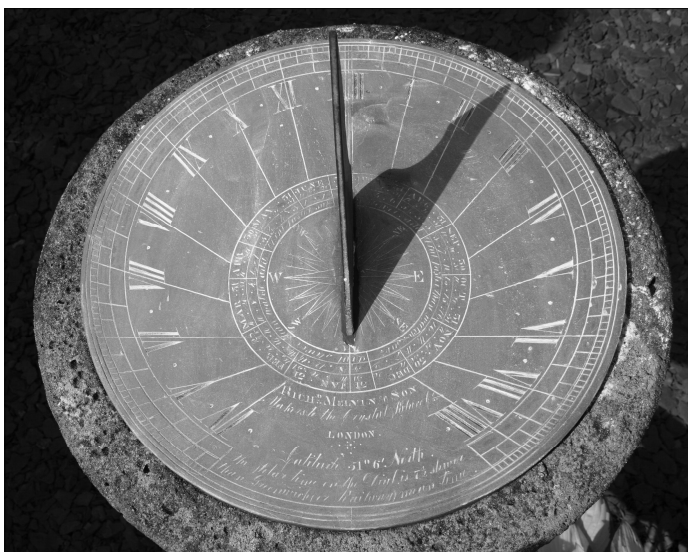

Fig 2 and 3. Two views of the dial plate, one (left) dusted with talcum powder.

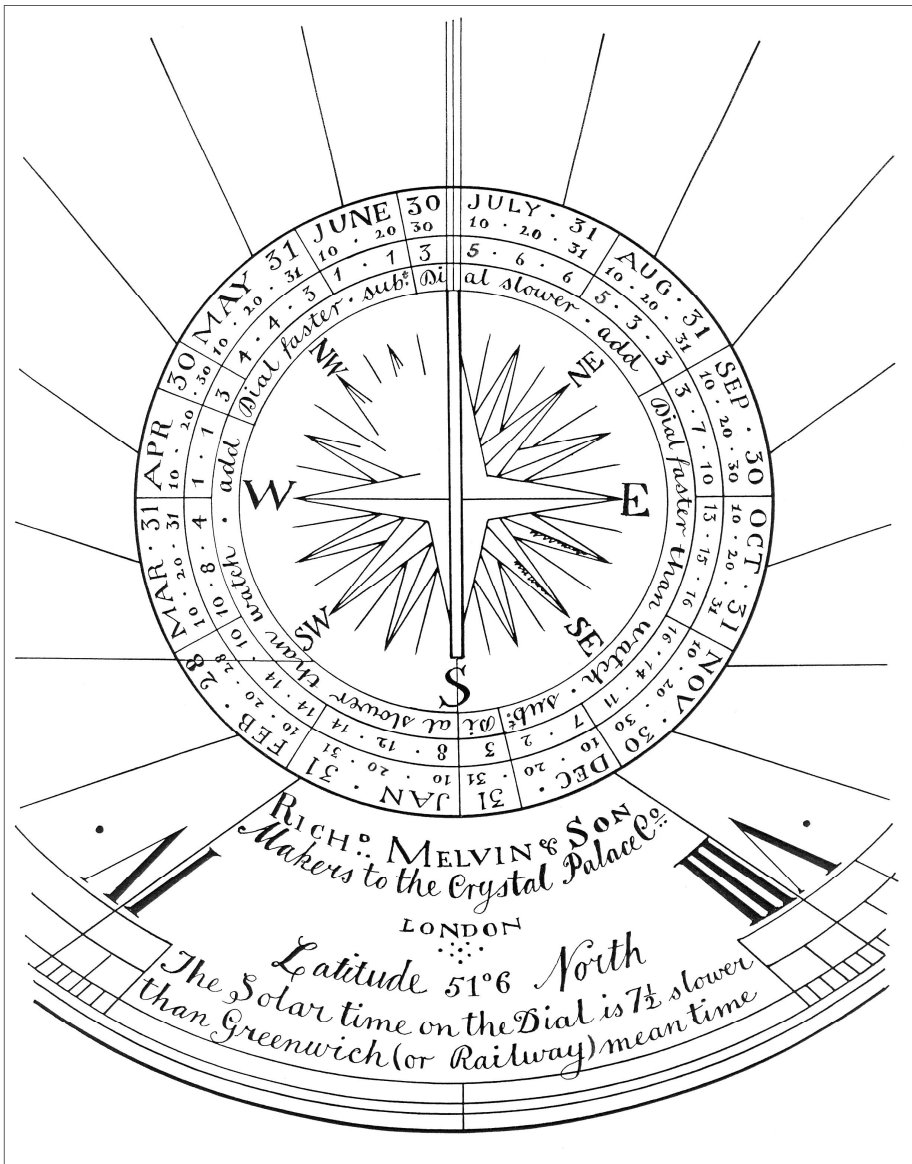

Fig 5. A careful copy of the lettering on the dial, originally drawn full size and shown here at approx. 65%.

proach fits with observations by others, as noted by Nicholls. There is also an engraving error where the 9am line continues through the equation of time ring. One wonders if this slight but obvious slip caused the dial to lose value or not be offered to the supposed client at 51° 6' N and 1° 56' W. In addition there are some lines at NW to N in the compass rose that appear to have suffered some localised weathering, and others at SE and ESE which could be erosion or indifferent engraving, see Fig 5. All the lettering and numerals have been traced from photographs of the dial and supplemented by direct examination. Similarly to Nicholls, the deciphering of some of the numerals, particularly the equation of time, may not be exact.

The fact that the gnomon angle is not for the latitude on the dial supports the opinion of Nicholls that there may have been a production line with a stock of various shapes and gnomons on the shelf, needing only the addition of latitude

Measured from dial photo	Theoretical latitude	
	53° 30'	51° 6'
-126.0	-125.7	-126.6
-108.5	-108.4	-109.0
-90.0	-90.0	-90.0
-71.5	-71.6	-71.0
-55.0	-54.3	-53.4
-39.4	-38.8	-37.9
-25.0	-24.9	-24.2
-12.5	-12.2	-11.8
0.0	0.0	0.0
12.6	12.2	11.8
25.0	24.9	24.2
40.0	38.8	37.9
55.0	54.3	53.4
72.0	71.6	71.0
90.0	90.0	90.0
108.0	108.4	109.0
125.0	125.7	126.6

Fig. 4. Table giving angles of hour lines (degrees, measured from the noon line) for the dial and for two theoretical latitudes.

and time difference from Greenwich to suit the buyer.

The equation of time ring has corrections that do not all correspond to modern values, but are consistent with other Melville dials.

Being circular is unusual for a Melville dial. Out of 36 records of dials, Michael Harley has only one other example that has been made as a circular dial, all the others are square, rectangular or octagonal.⁵ In addition to this uncommon feature, this particular dial is the only known example where Melville mentions a son, and in addition, the phrase “Makers to the Crystal Palace Co” dates the dial to about 1860.⁵

ACKNOWLEDGEMENTS

I am grateful for the owner of the dial, who, on clearing out a cupboard found a newspaper cutting, dated October 1996, about the theft and recovery from a ditch of the multiple gnomon Melville dial from Salisbury Cathedral Close. The Salisbury dial is recorded in the Register (SRN 2027) which notes that it was eventually sold. Prompted by the newspaper article, the owner tracked down our former Member-

ship Secretary, Robert Sylvester, who contacted me. The owner then, very obligingly, permitted examination and photography. Secondly, to Margery Lovatt who made a fair copy of the lettering of the original by hand, both to represent the detail and give an indication of Melvin's style, and thirdly to Michael Harley for additional information and comments.

REFERENCES and NOTES

1. R.A. Nicholls: 'A Dial by Richard Melville in Salisbury, Wilts', *BSS Bulletin* **95.2**, 27-31, (June 1995).
2. Michael J Harley and Harriet James: 'Five Sundials at Dunmore, Co. Donegal', *BSS Bulletin* **16(iv)**, 163-170 (December 2004).

3. The duality of naming dials by Melville/Melvin remains a puzzle. Jill Wilson's *Biographical Index of British Sundial Makers from the Seventh Century to 1920*, BSS, 2nd Edition, (2007) gives:

"MELVILLE Richard. A peripatetic and prolific maker of sundials, who signed and was known by a number of versions of his name. Ricardus Melville and Richard Melvin are recorded for example. He worked from a number of cities from 1832 to 1871."

Furthermore, Melville is his proper family name.

4. A.C. Carceres: *Private communication* (November 2006).
5. M.J. Harley: *Private communication* (November 2006).

Author's address:

douglas.bateman@btinternet.com

BOOK REVIEW

Catalogue of Sun-dials, Nocturnals and Related Instruments in the **Istituto e Museo di Storia Della Scienza, Firenze**. Compiled and written by Anthony J Turner. Published by Giunti Editore S.p.A, Firenze, ISBN 978-88-09-04999-4. Price €38 (£25 + p&p from Rogers Turner Books).

This soft covered catalogue has as its cover picture a polyhedral dial in front of a brass nocturnal. It lists the collection of sundials and related instruments housed in the Museum of the History of Science in Florence. It starts with a useful classification of sundials based on the work of Kathleen Higgins in 1953, and it generally follows this order. The two main divisions of the catalogue are: 1 Altitude Dials and 2 Direction Dials. Each of these sections are then sub-divided into types, e.g., for Altitude Dials, I Plane, II Cylinder, III Scaphe and IV Ring. These categories are further sub-divided into **a, b, c** etc., as necessary.

The catalogue commences with an Introduction which gives useful notes on various hour systems used, Babylonian, Italian, Astronomical etc. It also includes some notes on solar scales as found on certain instruments, particularly those of the Florentine Volpaia family. These notes gave me the clue to deciphering some odd markings on a universal equinoctial ring dial by Culpeper (to be published).

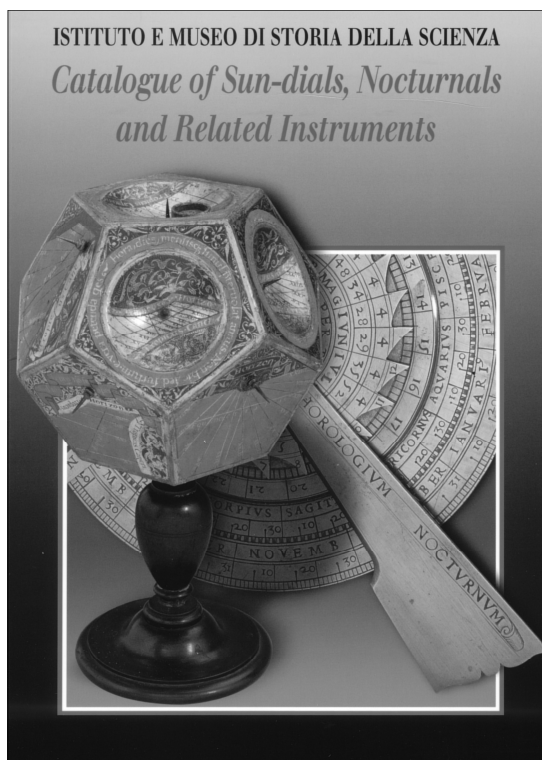

Following this is a section of 16 pages of colour plates.

The catalogue then follows starting with Altitude Dials as in the Higgins classification. The section on Quadrants is particularly interesting. (As these are often found on the rear of nocturnals, some of the instruments are merely listed here but are described fully in a later section.) The author even compares some of the decorative patterns on instruments with those taken from contemporary books.

The section on Direction Dials covers a wide range of types from several countries. Perhaps the most decorative and colourful of these are the multiple-faced polyhedral dials, a speciality of Florence, mostly signed or attributed to Don Stefano Buonsignori, and made around 1580. These dials have been extensively copied in recent years and modern replicas of these are often found.

The following section is on Nocturnals, many of these carrying a Quadrant on their reverse. The final short section, Miscellaneous, covers instruments such as sandglasses, an oil lamp clock, declinatories, dial making aids and perpetual calendars.

The three appendices cover missing instruments (those recorded in the Museum, but now lost - unfortunately in Italian), some notes about Vincenzo Viviani (1622 - 1703) who collected some of the instruments in the Museum and a list of magnetic declination values for Florence taken from the markings in the compass bowls of

these dials. The catalogue ends with a Bibliography of works cited in the text.

The initiative of producing catalogues of museum collections is admirable and needs to be actively encouraged. The Italians are particularly good at this and many fine catalogues may be obtained at the desks in their museums. This, as far as I am aware, is the first catalogue from the Museum in English. Generally, it follows the style and layout of previous catalogues, also published by Giunti. The current desire to put collections on the Internet, although commendable, is nowhere near as good as a proper catalogue published in book form.

The catalogue covers a very interesting collection of dials in the Museum in Florence. Their collection differs in many ways from those in other museums in that it has a very fine core of early instruments, particularly of Florentine manufacture, plus a few from some of the best English and German makers. The collection, however, does not cover (except in odd examples) some of the commoner dials that we would expect to find in museums such as Butterfield or Augsburg dials and the later French, German and English dials that we see almost everywhere.

My main criticism of the catalogue is with the presentation related to its illustrations. These are generally quite good but the points outlined below detract somewhat from this excellent book. Other catalogues in the series also suffer from many of these criticisms, so it is really to do with the 'house style' rather than an individual publication.

The illustrations are only identified by the catalogue number. The inclusion of a short title beneath each would have made identification much simpler and would have

reduced occasional confusion. Furthermore, the inclusion of the separate section of coloured pictures near to the front appears to be almost incidental *with no reference to them in the catalogue text*.

In some sections the pictures are often overleaf from the text and would have been much more useful included on the same page, or at least that facing the text. Some pages of illustrations are only half full and larger pictures showing more detail could have been used to fill them. In this particular catalogue, some of the descriptions are quite detailed and to understand these properly they need good illustrations. I found that in many cases the photographs were too small to show the necessary features, particularly of the quite complex quadrants. Larger, full page photographs or a few detailed shots here would have been welcomed.

The illustrations appear to have been taken before the catalogue was written and do not always show the dials from the most appropriate angles. For example, a cube dial is shown tilted along its east-west axis whereas it should only tilt north-south to set it to its correct latitude.

Considering the fact that this is an Italian publication, there are relatively few typographical errors, but I feel that additional proof reading by a native English speaker would have been worthwhile.

I would recommend this catalogue to anyone interested in the details of early portable dials, particularly quadrants and nocturnals. To those who have visited the Museum, or intend to do so, it is an invaluable aid and excellent reference material. I look forward to seeing more catalogues of this nature from some British museums.

Mike Cowham

A NEW SUNDIAL SOCIETY?

Christopher Daniel and **Hassan Ghazali** meeting at Greenwich during Mr Ghazali's visit to this country in June-July this year, when our Chairman showed him the sundials of the National Maritime Museum and the Royal Observatory. Mr Ghazali, from the City of Lahore in the Punjab, Pakistan, is a lawyer who trained in England and who works in the Planning & Development Department of the Government of the Punjab. In recent years, he became interested in sundials and plans to form a kindred society in Pakistan. Meanwhile, the BSS hopes to welcome him into the membership.



SCRATCH (MASS) DIALS: TIME FOR A REASSESSMENT

CHRIS H K WILLIAMS

As we all know, scratch dials (primitive early sun dials) survive in a bewildering variety of forms. They are the earliest time indicators to survive in any appreciable number – thousands have been recorded, not only in England but across Europe. As such it is most surprising they have not aroused more interest, appreciation and study amongst sun diallists, horologists or antiquarians in general.

I stumbled upon scratch dials by accident. Whilst researching the horological history of my local parish – Charing, Kent – I became aware that the local church had a barely visible scratch dial.¹ It was first recorded by Gerald Winzar in the 1970s. Failing health curtailed his recording activities and his partial Kentish survey lay dormant for 30 years until his widow afforded me the honour of bringing it into the public domain.² During these researches, I quickly devoured the classic scratch and mass dial texts – Horne, Greene and Cole. These only further aroused rather than satisfied my curiosity.

Soon after I joined the BSS. I was immediately struck by two facts. First, the Mass Dial Group's dedicated recorders had compiled a massive national database: a resource of enormous potential awaiting systematic analysis and investigation. Secondly, BSS members' interest in scratch dials appears surprisingly muted. A recent survey³ reported "...mass and Saxon dials are in a rather lowly 14th [out of 17] place, mass dials in particular seemed rather unloved...". Only humour, competitions and poems were less popular, and not by much! Examination of unpublished survey returns indicates that although 36% of respondents declared modest or strong interest in mass dials, 45% had little or none.⁴

Each fact of itself is surprising: valuable data does not usually remain uninvestigated for long in the modern age; also given that scratch dials and their predecessors account for the bulk of sundial and horological elapsed history, a less muted interest is only to be expected. Together the facts are paradoxical and anomalous. The uninvestigated potentiality of the database is surely the means to revive interest and appreciation. Most standard views and current received wisdom can be traced back to the interwar years. A reassessment is long overdue.

As a contribution to rehabilitating scratch dial interest and reviving scholarship, the mass dial database is being analysed. It is of a scale, coverage and detail that cannot but contain copious embedded information. Mathematical and

statistical methodologies hitherto unapplied in the study of scratch dials have been deployed. As a consequence, it is possible to rigorously address and answer in a quantified fashion questions such as

- How many dials have been recorded and how are they distributed by type?
- How many dials were there originally?
- How and why have dials been lost?
- How many dials remain to be discovered?
- How and why did dials change and evolve?
- What did dials look like originally?
- Why do we see multiple dials on churches?
- How and when were scratch dials affected by scientific sundials and clocks?
- Are there regional patterns, and if so, why?

As a result, a much fuller and richer insight into scratch dials – both their original prevalence, use, appearance and evolution as well as their eventual fate due to new technologies, church rebuilding and the elements – is emerging. Scratch dials have much to tell us that hitherto we have not heard.

Whilst a review of the scratch dial literature and much analysis has already been completed and some initial thoughts aired⁵, there is still considerable work in progress. It is planned that a complete and detailed write-up of all my researches be published eventually as a BSS monograph. In the interim, I am grateful for the Editor's suggestion and kind invitation to share briefly some of my findings on a regular quarterly basis.

REFERENCES AND NOTES

1. CHK Williams: 'Charing Clocks, Clockmakers and Clock-keepers' Parts I & II, *Archeologia Cantiana*, CXXV & CXXVI, 183-202 & 87-114 (2005 & 2006). See also 'The Church Clocks of Charing, Kent' *Antiquarian Horology*, 29, 371-396 (2006). These articles exhaustively list from medieval to modern times all known evidence, physical and documentary, of sundials associated with Charing Church.
2. CHK Williams: 'The Scratch Dials of Kent', *Archeologia Cantiana*, CXXVII, 333-356 (2007). Gerald Winzar's recordings have since been donated to the BSS archive.
3. BSS Readership Survey Results, distributed with *Bull BSS*, 18 (iii), (2006).
4. Returns provided courtesy of the Editor. Respondents ranked their interests from no interest (1) to very interested (5).
5. See note 2. Copies available via Tony Wood or the Editor.

HONORARY OFFICIALS OF THE BRITISH SUNDIAL SOCIETY

Patron: The Hon. Sir Mark Lennox-Boyd

President: Sir Francis Graham-Smith F.R.S.

Vice-Presidents: Mr David A. Young & Mr Frederick W. Sawyer III

COUNCIL MEMBERS

Mr C.St.J.H. Daniel
8 The Maltings
Abbey Street
FAVERSHAM
Kent ME13 7DU

(Chairman)
Tel: 01795 531804
chrisdaniel180@btinternet.com

Mr D.A. Bateman
4 New Wokingham Rd
CROWTHORNE
Berks., RG45 7NR

(Secretary)
Tel: 01344 772303
douglas.bateman@btinternet.com

Dr J.R. Davis
Orchard View,
Tye Lane
FLOWTON
Suffolk IP8 4LD

(Editor)
Tel: 01473 658646
john.davis@btinternet.com

Mr J. Foad
Greenfields
Crumps Lane
Ulcombe
Kent, ME17 1EX

(Membership Secretary)
Tel: 01622 858853
MemSec.BSS@keme.co.uk

Mr P. Powers
16 Moreton Avenue
HARPENDEN
Herts., AL5 2ET

(Registrar)
Tel: 01582 713721
patrick_powers@dunelm.org.uk

Mr G. Stapleton
50 Woodberry Avenue
North Harrow
Middlesex
HA2 6AX

(Treasurer)
Tel: 020 8863 3281
manaeus2000@yahoo.co.uk

Mr G. Aldred
4 Sheardhall Avenue
Disley
STOCKPORT
Cheshire, SK12 2DE

(Librarian and Restoration)
Tel: 01663 762415
graham-aldred@sheardhall.co.uk

Mr A.O. Wood
5 Leacey Court
CHURCHDOWN
Gloucester, GL3 1LA

(Mass Dials)
Tel: 01452 712953
aowood@soft-data.net

SPECIALISTS

Mr M. Cowham
PO Box 970
Haslingfield
CAMBRIDGE
CB3 7FL

(Advertising)
Tel: 01223 262684
ads@brownsover.fsnet.co.uk

Miss R.J. Wilson
Hart Croft
14 Pear Tree Close
CHIPPING CAMPDEN
Gloucs., GL55 6DB

(Biographical Projects)
Tel: 01386 841007
jill.wilson@ukonline.co.uk

Mr P Lane
7 Woodland Road
FOREST TOWN
Nottinghamshire
NG19 0EN

(Sales)
Tel: 01623 431865
bss-sales@ntlworld.com

Mr D.A. Young
Brook Cottage
112 Whitehall Rd
CHINGFORD
London E4 6DW

(Exhibitions and Acting Archivist)
Tel: 020 8529 4880
davidsun@davidyoung5.wanadoo.co.uk

Mr C. Lusby-Taylor
32 Turnpike Road
NEWBURY
Berks., RG14 2NB

(Webmaster)
Tel: 01635 33270
clusbytaylor@enterprise.net

Mr P. Nicholson
9 Lynwood Avenue
EPSOM
Surrey KT7 4LQ

(Internet Advisor)
Tel: 01372 725742
bss@pobox292.demon.co.uk

Mr J.M. Shaw
3 Millwood
Higher Bebington
WIRRAL
CH63 8RQ

(Newsletter Editor)
Tel: 0151 608 8610
jmikeshaw@ntlworld.com

Mr D. Pawley
8 Rosemary Terrace
Enborne Place
NEWBURY
Berks., RG14 6BB

(Newbury Mtg. Organiser)
Tel: 01635 33519
info@towertime.co.uk

